



Welcome to the University of Wollongong in Dubai

UOWD is a vibrant, dynamic and diverse institution, with a strong Australian heritage. Over our nineteen years of existence in Dubai, we stand proud as one of the oldest and most prestigious universities in the UAE, offering the best traditions of western education in a truly multicultural learning environment. We have gained an international reputation for the quality of our educational practices and are now recognized as an integral part of Dubai's academic landscape.

Combining the academic excellence of Australia's 12th highest ranking university with the culture and excitement of the cosmopolitan city of Dubai, we offer a dynamic, stimulating and rewarding learning environment. The UOWD campus is home to over 3,500 students from 105 countries being taught by academics of more than 35 nationalities

Our student-centred approach to learning ensures that our graduates are armed with not just technical knowledge, but also a range of professional skills – problem-solving, communication research, analysis and entrepreneurialism – that set them apart from their peers. Our 5,950 alumni include many high profile graduates in senior positions in public and private sectors across the region, bearing testimony to their high employability.

UOWD works closely with the University of Wollongong in Australia, which is ranked in the top 2% of universities worldwide. This longstanding tradition of academic excellence will enhance your educational experience and ensure that your time at UOWD will be an outstanding investment in your future, as we strive for even more exciting learning opportunities for our students.

So, welcome again to UOWD - your Australian university in Dubai.

The President

History of UOWD

The University of Wollongong in Dubai (UOWD) is one of the UAE's oldest and most prestigious universities. Established in 1993 by the University of Wollongong in Australia – currently ranked among the leading universities in the world – UOWD represented a very early Australian initiative in the Gulf region. From a small beginning opposite Al Mulla Plaza, through the landmark presence on Jumeirah Road, to the current location at Dubai Knowledge Village, UOWD is now recognised as being an integral part of Dubai.

As an independent UAE institution of higher education, UOWD attracts students not just from the UAE and Australia but from all over the world. Approximately 3,500 students representing over one hundred nationalities are currently enrolled at UOWD enjoying a quality academic experience.

UOWD offers a variety of specialist degree programs in four subject areas – Business and Management, Finance and Accounting, Computer Science and Engineering and Humanities and Social Sciences – each of which are directly linked to the human resource needs of the UAE.

All UOWD degree programs are accredited by the UAE Ministry of Higher Education and Scientific Research. In addition, the Australian Tertiary Education Quality Standards Agency (TEQSA) includes UOWD in its audits of UOW. The internationally recognised qualifications enable UOWD graduates to pursue rewarding careers in Dubai's burgeoning employment market. UOWD Alumni include many high profile graduates placed in prominent positions in both the public and private sectors across the region.

UOWD's Language Studies Centre offers language courses in English and Arabic. They range from English language study for University preparation to part time Arabic classes and English language teacher training. The Arabic program focuses on the cultural as well as the linguistic traditions, enabling participants to experience and enjoy Dubai's diverse heritage.

The University's faculty is a mix of locally and internationally recruited academics with extensive teaching, business and industry experience. They bring years of knowledge gained from research in their respective fields into the classroom providing students with a stimulating academic environment. Classes are small in number, allowing the lecturers to cater to the students' individual needs.

Since its inception, the University of Wollongong in Dubai has built a reputation for quality, credibility and integrity, and is held in high esteem by its students, alumni, business, industry and government. The institution maintains a long and proud tradition of excellence in education combined with liberal values of enquiry and continuously strives to provide a fertile environment for bright young minds to flourish, where critical thinking is both encouraged and nurtured. These are the qualities that characterise great institutes of learning.



OUR VISION

As an international-level teaching and research-oriented institution of higher-level learning, the University of Wollongong in Dubai is committed to:

1. making a significant contribution to educational and professional learning;
2. facilitating high calibre undergraduate and postgraduate students to pursue their educational goals, determine the direction of their lives, and contribute significantly to their profession, community, and society;
3. providing an international learning experience, so that students value cultural diversity;
4. recruiting academic and administrative staff who are of the highest quality, are committed to integrating the need for quality assurance with the need for change, promoting innovation and are creating an environment of continuous improvement.

It is against this background that the University has developed its vision: to be one of the top nationally accredited universities in the UAE.

We will be recognised for the high quality of our teaching as well as strong research activity (with outcomes that contribute to the development of the region), innovative degree programs (that are relevant and up-to-date), cultural diversity and valuable international connections, and effective engagement with commerce, industry, government and the UAE community.

Unlocking Potential through Learning is the guiding principle for all UOWD educational activities.

The University will achieve its Vision by pursuing the following Goals, to:

- Offer innovative, current and relevant programs that are accessible to a range of students, and deliver them with high quality teaching.
- Engage in high-quality research with outcomes that will benefit the region, and to have effective programs for research training.
- Have active collaborations with government, schools, industry, business and alumni, to enhance our research and teaching and build a strong support base for the University.
- Have a student body that is engaged with university life, satisfied with their experience, and well prepared for a career.
- Be a university community of international outlook, which provides our students with an international experience and students from other countries with the opportunity to learn about the UAE.
- Have the business capacity, systems and performance that enable us to reach our core goals effectively and efficiently.
- Recruit and retain skilled and motivated staff.

OUR VALUES

UOWD has adopted the following set of values, which guide the behaviour of staff in all parts of the University. These are also values we expect our graduates to develop and refine through their learning at UOWD.

Passion: we love what we do

Creativity: we are innovative and imaginative

Exceptional performance: we encourage everyone to shine; to go above-and-beyond

Collaboration: we share knowledge, expertise and resources

Integrity: we are honest, ethical and reliable

Courage: we speak our mind, take the initiative, and are steadfast in our decisions



INSTITUTIONAL GOALS

The University has identified the following goals as the key components of its vision to be one of the first-choice private Universities in the region.

1. UOWD Growth and Positioning. To build the University into a larger institution with an active doctoral research program and a broader range of disciplines, improve the University's standing and reputation in the MENA region, and make the University's programs more accessible in Abu Dhabi and other Emirates.
2. Preparing our Graduates. To offer innovative, current and relevant programs, deliver our programs with high quality teaching and make them accessible to a range of students; to have a student body that is engaged with university life, satisfied with the UOWD experience, and well prepared for a future career.
3. Research and Research Training. To engage academic staff and students in high-quality research with outcomes that will benefit the region, and to have effective programs for research training.
4. Partnerships and Community Engagement. To have active collaborations with government, schools, industry, business and alumni, to enhance our research and teaching and build a strong support base for the University. Facilitate closer connections and collaborations between the University of Wollongong (Australia) and the Gulf, Middle East, and surrounding regions.
5. Internationalisation. To be a university community of international outlook, which provides our students with an international experience and students from other countries with the opportunity to learn about the UAE.
6. Staff. To recruit and retain skilled and motivated staff.
7. Organisational Excellence. To have the business capacity, systems and performance that enables us to reach our goals effectively and efficiently.

LICENSURE & ACCREDITATION

The University of Wollongong in Dubai is officially licensed from 1 February 2008 to 31 January 2013 by the Ministry of Higher Education and Scientific Research of the United Arab Emirates to award degrees/qualifications in higher education.

All UOWD degree programs are accredited by the UAE Ministry of Higher Education & Scientific Research. In addition, the Tertiary Education Quality Standards Agency (TEQSA) includes UOWD in its audits of UOW.

UOWD degrees are recognised within the UAE, in GCC nations and internationally for further education and employment in the private and public sectors.

ORGANISATION CHART

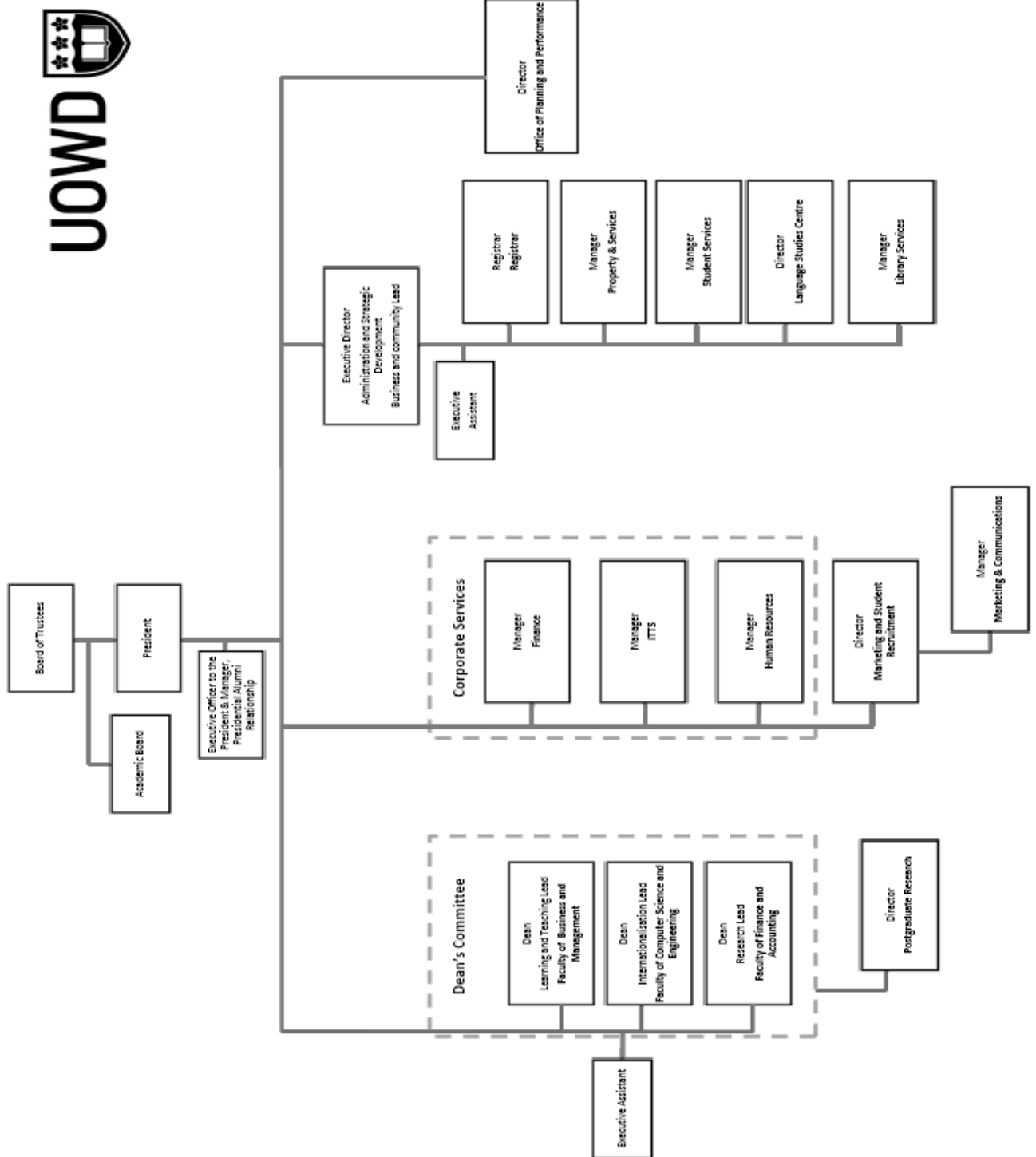



IMPORTANT INFORMATION FOR STUDENTS

Please ensure that you make yourself aware of the University's rules, policies and procedures prior to enrolling on your program of study.

You can find details of all the relevant policies at <https://my.uowdubai.ac.ae/policies/index.php>

In particular, please note the following key points:

- SOLS is the official communication channel of the University and you should ensure you check your account on a regular basis.
- It is your own responsibility to ensure you enrol in the relevant subjects for each semester. It is not possible to enrol in a subject after the second week of the semester, except in exceptional circumstances and only with the permission of the Dean and the Registrar.
- Electronic "Manual Enrolment" is only available for final semester students requiring a place in a core subject that has reached full quota during online enrolment.
- Prior to enrolling, you should ensure that you meet the pre-requisites for each course. If you enrol in a subject for which you do not satisfy the pre-requisites, you will not be allowed to continue with the course.
- You are advised to follow the subject sequence schedule provided at enrolment and consult with your Academic Advisor if you have any queries or concerns in relation to this.
- You should check the Final Exam timetable for any clashes before enrolment as it is not possible to make any changes once the final schedule is published.
- In order to continue with your degree program, you will need to meet the Minimum Rate of Progress (MRP) each semester. Please refer to MyUOWD for full details of the MRP policy.



FACULTY OFFICE

Faculty of Business & Management

Dean	Dr Laubie Li Room 3-24, Block 15, Knowledge Village Tel: 04 367 2452 / 2461 E-mail: LaubieLi@uowdubai.ac.ae
Faculty Co-ordinator	Ms Tara O Flaherty Room 3-23, Block 15, Knowledge Village Tel: 04 367 2452 E-mail: TaraOFlaherty@uowdubai.ac.ae

Faculty of Finance & Accounting

Dean	Prof David Goodwin Room 3-25, Block 15, Knowledge Village Tel: 04 367 2441 E-mail: DavidGoodwin@uowdubai.ac.ae
Faculty Co-ordinator	Mr Ivan D'Souza Room 3-23, Block 15, Knowledge Village Tel: 04 367 2441 E-mail: IvanDSouza@uowdubai.ac.ae

Faculty of Computer Science & Engineering

Dean	Dr Mohamed Salem Room 3-26, Block 15, Knowledge Village Tel: 04 367 2443 E-mail: MohamedSalem@uowdubai.ac.ae
Faculty Co-ordinator -	Ms Maria Pereira Room 3-23, Block 15, Knowledge Village Tel: 04 367 2443 E-mail: MariaPereira@uowdubai.ac.ae
Office Reception	Ms. Shahrzad Abassi Tel : 04-375 3061
Student Relationship Officer	Mr. Rahul Bijlani Tel: 04 375 3061 RahulBijlani@uowdubai.ac.ae

WELCOME FROM THE DEANS

Dear Students,

Welcome to the Spring 2013 semester and, to our new students, a warm welcome to the University of Wollongong in Dubai and our campus. You are now part of the "UOWD family" which consists of approximately 3,000 students from more than 80 countries.

At UOWD, our aim is to equip you with the diverse skills and knowledge that you require to have a successful professional career in the corporate world. To do this, we have developed programs and subjects that will not only teach you the theory, but also allow you to put it into practice. To maximize your academic potential, you need to demonstrate a commitment to your studies. We are here to help you build the foundation for your future career, which requires your active participation and steadfast dedication. This means attending class regularly, taking part in discussions and activities, working together in teams, completing assignments on time and developing regular study habits. Your lecturers and many other people at the university will provide you with the support you need to do this, however, at the same time, you need to take responsibility for your learning and development. Education involves both teaching and learning, requires both a teacher and a student! During your studies you will be challenged and supported so that you can learn and develop your competencies and expertise.

The purpose of the Degree Planner is to guide you through your career as a student. Make yourself familiar with it. It contains important information about your degree, the subjects you will enroll in and the university's rules and regulations. The last section of the Degree Planner allows you to write down your personal degree plan based on the recommended subject sequence, which you are strongly encouraged to follow. You can also make a note of your class timings, assessment due dates and final exam information in the last section. Remember – this is your plan for success! Don't stray from it.

The previous page provides you with the contact information for the people who can help you and support you during your studies. Please meet with your Academic Advisor to discuss your progress on a regular basis. They can assist you with your degree plan. If you are having difficulties with academic skills such as preparing for exams, managing your time, or writing essays and reports, visit the SASS office (block 5) to find out which workshops you can attend to improve your study habits. If you have any suggestions for activities we can organize to enrich your learning experience, please let us know.

Best wishes for a successful and productive Spring 2013 semester!

Deans

TABLE OF CONTENTS

	PAGE
About the Faculties	1
1.1 Academic Responsibilities of the Faculties	1
1.2 Contacting the Faculty Office	2
1.3 Faculty Website	3
1.4 Faculty Noticeboards	4
General Information for Students	5
2.1 Locale	5
2.2 Resources	5
2.3 Admission Requirement	5
2.4 Tuition Fees	5
2.5 Academic Calendar Dates	5
2.6 Academic Advising	7
2.7 Student Services	8
2.8 Student Academic Support Services (SASS)	8
2.9 Plagiarism	8
2.10 Turn It In	9
2.11 Code of Conduct	9
2.12 Resolving Complaints	9
2.13 Feedback	9
Information Related to Enrolment	10
3.1 Graduate Foundation Courses (GFC)	10
3.2 Credit Point System	10
3.3 Subjects per Semester	11
3.4 Subject Sequence	11
3.5 Advanced Standing	11
3.6 Enrolment using Student On-Line System (SOLS)	11
3.7 SOLSMail	12
3.8 Pre-Requisites	12
3.9 Exclusions	12
3.10 Variations to Enrolment	13
3.11 Minimum Passing Requirements	14
3.12 Minimum Rate of Progress (MRP)	15
3.13 Special Consideration	15
3.14 Release of Final Results	15
3.15 Re-Evaluation Requests	16
3.16 Graduation Requirement	16
3.17 Application for Graduation	16
3.18 Graduation with Distinction	17
3.19 Academic Misconduct	17
3.20 Amendment of Academic Record	17
3.21 Leave of Absence	17
3.22 Transfer to UOW Campus	17
3.23 Articulation to another Degree	17
FACULTY STAFF INFORMATION	18
PROGRAM INFORMATION	21
4.1 Master of Business Administration (MBA)	21
4.2 Master of International Business (MIB)	24
4.3 Master of Quality Management (MQM)	26

TABLE OF CONTENTS (CONTD)

4.4 Master of Strategic Marketing (MSM)	28
4.5 Master of Strategic Human Resource Management (MSHRM)	30
4.6 Master of Science in Logistics (MSL)	32
4.7 Master of Applied Finance & Banking (MAFB)	34
4.8 Master of Engineering Management (MEM)	36
4.9 Master of Information Technology Management (MITM)	39
5.0 Master of International Studies	42
5.1 Master of Media and Communications	43
SUBJECT DESCRIPTIONS	45
SUBJECT OFFERING LIST	70

ABOUT THE FACULTIES

The four faculties of the University of Wollongong in Dubai i.e Faculty of Business & Management (FBM), Faculty of Finance & Accounting (FFA), Faculty of Computer Science & Engineering (FCSE) and Faculty of Arts & Humanities (FAH) are dedicated to excellence in teaching, research and service. We are preparing tomorrow's leaders today by offering top quality postgraduate programs in a number of discipline areas. Programs include:

Faculty of Business & Management :

- Master of Business Administration (MBA)
- Master of International Business (MIB)
- Master of Quality Management (MQM)
- Master of Strategic Human Resource Management (MSHRM)
- Master of Strategic Marketing (MSM)
- Master of Science in Logistics (MSL)

Faculty of Finance & Accounting :

- Master of Applied Finance & Banking (MAFB)

Faculty of Computer Science & Engineering :

- Master of Information Technology Management (MITM)
- Master of Engineering Management (MEM)

Faculty of Arts & Humanities :

- Master of International Studies (MIST)
- Master of Media and Communications (MMC)

Our dedicated and qualified faculty provides our graduate students with the complex skills and competencies demanded in today's global economy in order to be able to serve the rapidly changing demands of the young GCC countries in the new century.

This Degree Planner is developed to provide you with relevant information concerning your degree and a structure to assist you in planning your program of study.

1.1 Academic Responsibilities of the Faculties

The four faculties (FBM, FFA, FCSE & FAH) deal with all academic matters related to postgraduate programs at UOWD, which include the following:

1. Academic advice about programs, majors and subjects
2. Approvals for enrolment and withdrawal of subjects after the general deadlines (in exceptional circumstances only)
3. Approvals to change a degree program
4. Advanced standing
5. Supplementary final exam requests
6. Requests for re-evaluation of final exams
7. Academic issues regarding delivery of subjects

Other issues such as (scholarships, leave of absence, letter requests, graduation eligibility and visas) are the responsibility of the Registrar's department.



1.2 Contacting the Faculty Office

General Faculty Enquiries

Most of your questions regarding Academic processes and procedures will be answered in the 'Frequently Asked Questions' or 'Forms and Processes' link through MYUOWD. For detailed information, visit the Policies link on the website. If you are still unsure after visiting these links, please contact the Faculty Office.

Academic Advice Enquiries

Academic Advice can include clarifications on degree planning, advice with choosing electives, advice with selecting your major and providing information about academic resources at UOWD. Students are required to make an appointment to meet with the Academic Advisors for their programme. Available office hours are posted online on the UOWD website, on office door and available on the Faculty Office noticeboard.

Subject Enquiries

Any enquiries related to individual subjects (e.g. assignments, lecture materials, etc.) should be directed at your subject lecturer during their consultation hours which are available in the subject outline and also posted on their office door. If students require to meet with a lecturer at other timings then they should contact the lecturer by e-mail or telephone to make an appointment.

Program Enquiries

Students who have general questions about a particular program of study can meet with their Associate Dean / Academic Advisor who are available by appointment only.

Master of Business Administration (MBA)

Master of Quality Management (MQM)

Master of International Business (MIB)

Master of Strategic Marketing (MSM)

Master of Strategic Human Resource Management (MSHRM)

Master of Science in Logistics (MSL)

Until further notice, all the above mentioned programs will be covered by :

Dr. Arijit Sikdar, Associate Dean FBAM

ArijitSikdar@uowdubai.ac.ae

Room No 2-12, Block 15

Tel: 04-390 0408

Master of Engineering Management (MEM)

Dr. Kamal Jaafar

KamalJaafar@uowdubai.ac.ae

Room No.1-30, Block 15

Tel: 04-369 3019

Master of Information Technology Management (MITM)

A/Prof Nawar Hakeem

Room No. 2-04, Block 15

Tel: 04-367 2475



Master of Applied Finance & Banking (MAFB)

Dr. Naeem Muhammad
NaeemMuhammad@uowdubai.ac.ae
Room No.2-07, Block 15
Tel: 04-367 2423

Dr. Lamia Obay
LamiaObay@uowdubai.ac.ae
Room No.1-24, Block 15
Tel: 04-390 0480

Master of International Studies (MIST) & Master of Media and Communications (MMC)

Dr. Feras Hamza
FerasHamza@uowdubai.ac.ae
Room No. 2-10, Block 15
Tel: 04-375 1271

SOLS EMAIL COMMUNICATION

- You will be allocated an email account which is the official communication tool for both students and the University.
- Any student making an email request, must do so using their University mail account.
- You will regularly receive emails from the University via your SOLS account. We will not accept any responsibility, should you not check your SOLS account.
- Requests from personal emails will not be processed.

1.3 Faculty Website

Any important information related to the Postgraduate Degrees will be available through the MyUOWD website:

<http://my.uowdubai.ac.ae>

Students are strongly advised to check the MyUOWD website and noticeboard on a regular basis for important information about subjects, classes and timetables. It is the students' responsibility to ensure they contact the University regarding any problems and information that they require. Please contact the ITTS department in Block 5 if you are having problems with accessing MyUOWD.

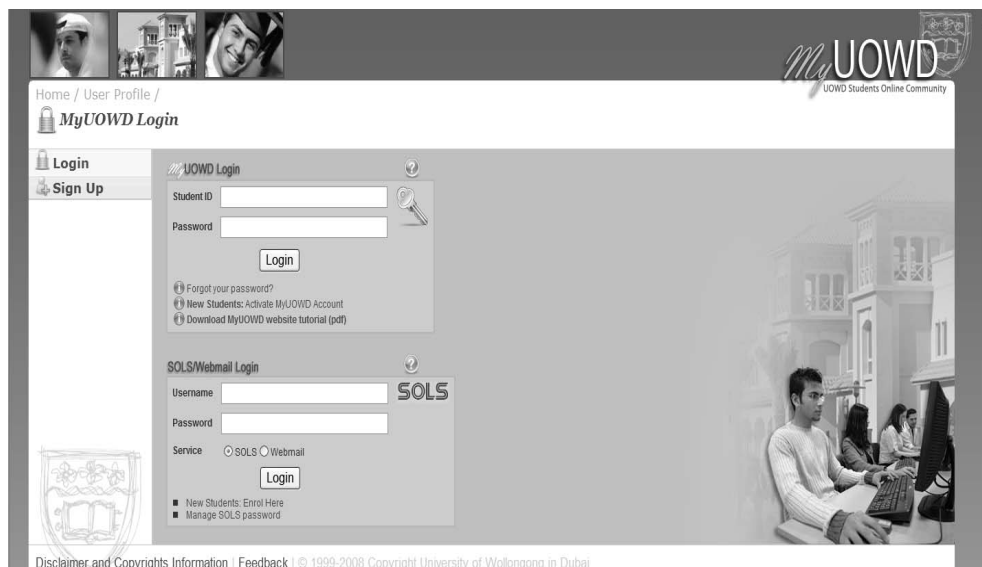

The following is available on the MyUOWD website:

Subject Folders

Each subject folder contains lecture noters, slides and additional materials to assist with studies. Students are advised to check their subject folders for updated materials, notices and other information provided by the lecturer on a daily basis. Click on the *My Subjects* link to access the subject folder.

Timetables

All of the timetable information related to class timings and dates of final exams can be downloaded from the MyUOWD website by clicking on the *Timetables* link. The timetables are posted on this site before the start of the semester and **it is the students' responsibility to check the class timings and the final exam dates BEFORE enrolling in a subject and up until the end of week 2 of session** to ensure that there are no clashes. It is not possible to enrol in two subjects which have clashes in the class timings or in the final exam dates. Once the timetables have been published and finalised, it is not possible to make changes to timings.

Notices

Regular notices are posted on the Faculty website to inform students about upcoming changes and any other relevant information. **Students must check the Notices on the website at least once per day.** Any information about re-scheduling of classes due to holidays, start of enrolments and unscheduled public holidays are also posted on the Notices section of the website.

Policies and Rules

You can access the Policies and Procedures online. Click on the *Policies* link on MYUOWD for more information. You can also become familiar with our processes via the '**Frequently Asked Questions**' or '**Forms and Processes**' link through MYUOWD.

It is the students' responsibility to become familiar with all of the relevant policies, including (but not limited to):

- Assessment Policy
- Special Consideration
- Minimum Rate of Progress
- Plagiarism Policy
- Ethical Code of Conduct- Students
- Academic Grievance Policy

1.4 Faculty Noticeboards

In addition to the MyUOWD website, relevant faculty information is also posted on Faculty noticeboards around the campus. The main noticeboard is located outside the Faculty Office (Room 3-23) in Block 15. Students are strongly encouraged to check these noticeboards on a regular basis to ensure that they are aware of important information and updates.



GENERAL INFORMATION FOR STUDENTS

This section provides a general overview of the relevant information and policies related to studying at UOWD. Students should refer to the Academic Calendar and Student Handbook available on the UOWD website for detailed information.

2.1 Locale

The University of Wollongong in Dubai is located in the hub of Dubai Knowledge Village; an easy drive from the heart of Dubai and international airport. A variety of services are available on campus ranging from a fully-equipped library, computer labs and medical centre through to games rooms, coffee shops and public facilities. More details regarding services and facilities, can be found in the Student Handbook or by visiting the University's website: www.uowdubai.ac.ae

2.2 Resources

The University has a wide variety of resources available to students whilst enrolled and to Alumni, which can be accessible post graduation. These include a comprehensive library with over 60,000 e-books and 25,000 hard copies, besides CDs and 70,000 online journals; separate male and female accommodation located at The Gardens opposite Ibn Battuta Mall; transport to and from residences and local metro station; computer labs and printing services. In addition the Student Services Department (SSD) offer a range of services to students including career development, health services and medical centre, counselling, student clubs and associations and sport and recreation activities. Detailed information is available at the University's website: www.uowdubai.ac.ae and within the Student Handbook.

2.3 Admission Requirements

All students seeking admission to the University of Wollongong in Dubai must meet the academic and English language requirements as outlined in the Admissions policy PP-REG-DB-5.1 which is available at www.uowdubai.ac.ae. Application for admission generally closes 4 weeks prior to the commencement of session, however late applications may be considered. Students seeking credit transfer (advanced standing), based on studies completed at another institution, are required to submit subject outlines with their application for admission. The Advanced Standing policy is available at the MyUOWD website.

Should a student's enrolment lapse, or if a student has been discontinued, an Application for Admission form must be submitted to Student Recruitment for consideration of re-admission.

2.4 Tuition Fees

Tuition fees must be paid each session according to the number of subjects taken. The amount of fees to be paid depends on the fee payment plan opted by the student. Students can pay fees by cash, cheque or credit card. Late payment of tuition fees will be subject to a penalty of AED 50 per subject, per week. Tuition fees do not cover books or other associated study costs. Fees are charged for services eg. official letters, ID replacement cards etc. A full list of charges can be viewed at: <http://www.uowdubai.ac.ae/ps/details.php?sec=3,6>. Detailed fee information, including refunds and transfers can be found under How Much Will it Cost and the Academic Calendar, both available at www.uowdubai.ac.ae. Fee refund and transfer information can be obtained in the Fee Policy: F-DB-FIN-5.1.

2.5 Academic Calendar Dates

Please note that the academic calendar listed below is subject to change. Students must check the UOWD website (www.uowdubai.ac.ae) and follow the *Current Students* link, then *Important Dates* for the most up-to-date version of the academic calendar. Classes and examinations may be affected by public holidays and notices for make-up dates will be posted on the MyUOWD website. Please note that regular as well as make-up classes may be held on weekends or in the evenings on week days.

NOTE: This is a draft calendar and is subject to change. Please check the website for the most up-to-date version of the calendar. Classes and examinations may be affected by religious public holidays and notices for make-up dates will be announced on the website.

Spring Session 2013

26 January	Postgraduate	Orientation & Enrolment
29 January	Undergraduate	
31 January	<i>^ Tuition fees due; 100% refund</i>	
3 February – 16 March	Lectures commence (6 weeks)	
16 February	Last day to enrol	
23 February	<i>^ Transfer of fees-100%; Refund-less 25% tuition fees</i>	
17 - 23 March	Study break / make-up classes	
24 March – 11 May	Lectures recommence (7 weeks)	
6 April	Last day to withdraw	<i>^ Transfer of fees-less 20% tuition fees; no refunds</i>
12 – 18 May	Study break / Make-up classes	
19 May – 1 June	Exams	
13 June	Results posted on SOLS	
17 June	Supplementary exams commence	

Summer Session 2013

12 May (6.00 pm)	Pre-enrolment for re-enrolling students	
1 June	Postgraduate	Orientation & Enrolment
3 June	Undergraduate	
6 June	<i>^ Tuition fees due; 100% refund</i>	
9 June – 3 August	<i>*Lectures commence (8 weeks) * Postgraduate students will be required to attend one (1) Saturday class during Summer – details available on timetable</i>	
15 June	Last day to enrol	
22 June	<i>^ Transfer of fees-100%; Refund-less 25% tuition fees</i>	
13 July	Last day to withdraw	<i>^ Transfer of fees-less 20% tuition fees; no refunds</i>
4 – 10 August	Study break / Make-up classes	
11 -17 August	Exams	
22 August	Results posted on SOLS	
26 August	Supplementary exams commence	

Autumn Session 2013

5 August (6.00 pm)	Pre-enrolment for re-enrolling students	
7 September	Postgraduate	Orientation & Enrolment
11 September	Undergraduate	
12 September	<i>^ Tuition fees due; 100% refund</i>	
15 September	Lectures commence (4 weeks)	
28 September	Last day to enrol	



5 October	[^] Transfer of fees-100%; Refund-less 25% tuition fees	
13 - 19 October	Study break / make-up classes	
20 October	Lectures recommence (9 weeks)	
16 November	Last day to withdraw	[^] Transfer of fees-less 20% tuition fees; no refunds
22 – 28 December	Study break / Make-up classes	
29 December – 11 Jan	Exams	
23 January	Results posted on SOLS	
27 January	Supplementary exams commence	

[^] Students MUST withdraw from their subject/s via SOLS prior to submitting their fee refund/Transfer form	
PUBLIC HOLIDAYS : Students will be advised of make-up dates for classes falling on public holidays or where the University will be closed on a business day in lieu of public holidays falling on a weekend day.	
1 January – New Year's Day	15 October - Eid-al-Adha (Feast of the Sacrifice)**
24 January - Mouloud (Birth of the Prophet)**	4 November - Al-Hijra (Islamic New Year)**
6 June - Leilat al-Meiraj (Ascension of the Prophet)**	2 December – National Day
8 August - Eid-al-Fitr (end of Ramadan)	25 December – Christmas Day
<i>** Islamic holidays are subject to change and will be confirmed once official Government announcements are made. Travel arrangements should only be made following these announcements.</i>	

Important information regarding session dates

1. Students can add/withdraw from subjects through SOLS until the last day of the first week of the semester (Autumn/Spring/Summer). No new subjects can be added after this date.
2. Students who have not paid their fees by last date for payment will be automatically withdrawn from the subjects for which the fees are outstanding. Students will not be allowed to enrol in those subjects again in that particular semester.
3. Students will not be allowed to withdraw from a subject without academic penalty (i.e. a FAIL grade) after the specified date.
4. Students who withdraw may obtain a fee refund or transfer the fees to the following semester subject to conditions. A portion of the fees may be refunded/transferred depending on the subject withdrawal date. Students should read the Fee Policy available at myUOWD website.
5. The University offers several payment options for tuition fees. Students opting for a specific payment plan will receive a schedule of due dates for payments each semester from the Cashier.

2.6 Academic Advising

All students must consult with their Academic Advisor **at least once every semester**, and before enrolling in any subjects. The academics' role is to assist students with their degree planning and ensure that students are following the recommended subject sequence. Students are expected to initiate and maintain contact with them to discuss their progress and academic performance. Some of the help they provide is as follows:

- Being the first contact for students seeking academic inquiries / requests
- Assistance with degree planning
- Selecting the right subjects to enroll in each semester
- Giving advice with choosing electives
- Approving program (degree) changes, assistance with selecting a major
- Providing information about academic resources at UOWD
- Clarifying academic policies
- Discussing academic progress

It is the students' responsibility to seek answers to their questions, check SOLS on a regular basis to verify the status of their enrolment, adhere to scheduled appointments and follow through on recommendations made by Academic Advisors.

2.7 Student Services

The Student Services Department (SSD) at UOWD seeks to create a healthy and enjoyable learning environment, while enriching the learning experiences for all UOWD students. SSD plays a vital role in campus community life. The Department provides career and personal counselling services and referrals, career development advice and placement assistance, student extracurricular activities, student clubs and associations, sports and recreational programs, health services and student residences. For further information, students should refer to the SSD website: www.uowdubai.ac.ae/ss

2.8 Student Academic Support Services (SASS)

The Student Academic Support Services (SASS) provides a range of learning development services aimed at improving student learning. Through workshops and seminars, students are encouraged to develop critical thinking and analysis skills, which in turn will enhance their academic potential. SASS offers regular learning development workshops which are free for all UOWD students. Workshop topics include the following:

- Avoiding Plagiarism
- Academic Writing: Essays & Reports
- Exam Preparation
- Critical Thinking
- Using TurnItIn
- Academic Research
- Listening & Note-taking Skills
- Memory Strategies

A full list of workshops on offer in a particular session is available on the SASS website. To register for a SASS workshop, students must send an e-mail to SASS@uowdubai.ac.ae and include their name, contact number and the title of the workshop they wish to attend. SASS also provides Peer Tutoring Program and Academic Writing Skills sessions.

Students can also make appointments with the SASS Administration Assistant for individual consultations. Students are encouraged to visit the SASS website regularly for news and updates.

SASS Contact Information

Room 32A, Ground Floor, Block 5

Tel: (04) 390 0602

E-mail: SASS@uowdubai.ac.ae

<http://www.uowdubai.ac.ae/ss>

2.9 Plagiarism

Plagiarism means using the ideas of someone else without giving them proper credit. That someone else may be an author, critic, journalist, artist, composer, lecturer, tutor or another student. Severe plagiarism is defined as submitting work which is wholly copied from someone else without proper acknowledgement. Unintentional plagiarism can result if students do not understand and use acceptable scholarly methods of acknowledgement (in-text citation). In either case, whether intentional or unintentional, severe penalties may be imposed on the student. When it is desirable, or necessary, to use other people's material, students must ensure they include appropriate references and attribution. Students must ensure they are familiar with the Plagiarism policy which is available on the MyUOWD website.



Plagiarism constitutes serious academic misconduct. Plagiarism will not be tolerated and may lead to expulsion from the University. Students must particularly take care to avoid unintentional plagiarism.

2.10 TurnItIn

TurnItIn is an online text-matching system used by the University to prevent plagiarism. Students must submit all written assignments through TurnItIn which will generate an "Originality Report" indicating the sources used in the document. TurnItIn is available online at www.turnitin.com. To access TurnItIn, every student must have a TurnItIn account. It is the student's responsibility to create a TurnItIn account after they have been provided with a Class ID and password by their lecturer. This account should be used for the duration of the student's enrolment at UOWD. It is not necessary to create a new account every semester.

Failure to submit an assignment through TurnItIn will result in marks for the assignment being withheld. Students do not need to hand in a printed copy of the TurnItIn Originality Report unless requested to do so by the lecturer.

More information about TurnItIn requirements (including how to add a class) are provided in the first lecture of each subject. Students can also download Frequently Asked Questions (FAQs) about TurnItIn from the SASS website (www.uowdubai.ac.ae/ss).

2.11 Code of Conduct

UOWD is committed to providing a safe and orderly environment for the University community, and expects each member of that community to behave responsibly and ethically. Rules exist to seek support of achieving this goal by providing a clear and transparent process for dealing with alleged student misconduct. The full policy and implications for breaching the Student Conduct Rules can be located at the student intranet: www.uowdubai.ac.ae/cs/index.php

2.12 Resolving Complaints

The University aims to provide a fair, equitable and a productive learning environment for all its students. The achievement of this goal is by providing a transparent and consistent process for resolving student grievances. The Academic Grievance – Students (PP-ACD-DB-10.3)

2.13 Feedback

To supplement our regularly scheduled slate of surveys, the Office of Planning and Performance (OPP) maintains a continuous feedback opportunity to UOWD students, staff and visitors through standardized comment forms. These are collected on a regular basis and forwarded to the relevant manager or dean for response to the issue. The OPP tracks all actions related to the comment and subsequent action. In addition, students are encouraged to view relevant policies should they have an academic complaint they would like to lodge. Policies are available at www.uowdubai.ac.ae/cs/index.php

INFORMATION RELATED TO ENROLMENT

This section provides a general overview of the relevant information and policies related to studying at UOWD. Students should refer to the Academic Calendar and Handbook available on the MyUOWD website for detailed information. **Enrolment is the student's responsibility** and students must be aware of their enrolment status at all times. Any queries regarding enrolments should be directed to the Registrar's department in the first instance.

3.1 Graduate Foundation Course (GFC)

The objective of the Graduate Foundation subjects is to provide students with fundamental knowledge deemed necessary to enrol in postgraduate programs if no such prior knowledge has been covered during previous studies.

The University of Wollongong in Dubai currently offers a wide range of preparatory subjects in the areas of Accounting, Finance, Marketing, Operations Management and Statistics as general foundation subjects for all students wishing to enrol in postgraduate studies. Each GFC subject has a set of defined learning outcomes and is formally assessed through case studies, problem solving during tutorial sessions and final exams.

Operationally and at admission time, each students' record is analysed and the relevant foundation subject/s are recommended. Applicants who are required to undertake Graduate Foundation subjects will need to:

- Meet with their academic advisors during Orientation and Enrolment to select GFC subjects.
- Successfully complete each of the applicable subjects no later than the end of their first semester to be able to continue studies at UOWD.

Each Graduate Foundation Course subject is delivered over six weeks and generally, 2 GFC batches per subject run during each regular semester. In addition to in-class contact hours, students will be required to complete tasks as assigned by their lecturer, complete the reading material, and prepare for exams.

To successfully complete a GFC subject, students must obtain a minimum of 50% in the final exam. The results will be posted on SOLS within 2 weeks and students can access the results directly.

3.2 Credit Point System

Credit points are a basic measure of workload. All subjects are given a credit point value, which is normally 6. Credit points refer to the value attached to each subject undertaken as part of a degree. Credit points are also a guide to the number of hours per week you should be studying the subject. Most subjects are single session (half-yearly) duration, offered in autumn or spring session, and normally have a value of 6 or 8 credit points. Double session (annual) subjects usually have a value of 12 credit points. Each credit point has an implied workload of 26 hours over the duration of the subject. For example, for a 6 credit point single session subject you should spend a total of 12 hours per week in attending classes and working on your own for that subject (i.e. 6 credit points x 26 hours ÷ 13 weeks = 12 hours).

Postgraduate degrees have the following credit point values –

DEGREE	CORE	ELECTIVES	TOTAL CREDIT POINTS
MBA	9 core at 6 cp each	3 electives at 6 cp each	12 subjects with a total of 72 cp
MIB	7 core at 6 cp each	3 electives at 6 cp each	10 subjects with a total of 60 cp
MQM	5 core at 6 cp each	3 electives at 6 cp each	8 subjects with a total of 48 cp
MSM	6 core at 6 cp each	2 electives at 6 cp each	8 subjects with a total of 48 cp
MSHRM	6 core at 6 cp each	2 electives at 6 cp each	8 subjects with a total of 48 cp
MEM	8 core at 6 cp each	2 electives at 6 cp each	10 subjects with a total of 60 cp
MITM	8 core at 6 cp each	2 electives at 6 cp each	10 subjects with a total of 60 cp
MAFB	8 core at 6 cp each	2 electives at 6 cp each	10 subjects with a total of 60 cp
MSL	6 core at 6 cp each	2 electives at 6 cp each	8 subjects with a total of 48 cp
MIST	5 core at 8 cp each 1 core at 16 cp	3 or 4 electives at 6 or 8 cp each: minimum 20 cps	9 or 10 subjects with a total of 76 cp
MMC	5 core at 6 cp each 1 core at 12 cp	3 electives at 6 cp each	9 subjects with a total of 60 cp

3.3 Subjects per Semester

PG Students can use SOLS to enrol online. The normal full-time load is 24 credit points (4 subjects) per semester, however, students may enrol on a part-time basis. On average students enrol in 2 subjects per semester to avoid the high study work load. It's advisable to consult with your Academic Advisor before enrolling online in more than 2 subjects. In MIST and MMC, maximum per semester is two subjects.

3.4 Subject Sequence

Students must follow the subject sequence provided in this Degree Planner to complete the degree requirements. Students who fail to follow the prescribed sequence of subjects risk delaying their graduation, and meeting pre-requisite requirements. Students who fail a subject and, therefore, fall out of sequence, must see an Academic Advisor. Please note that failure to follow the subject sequence may result in timetable clashes and subsequently graduation delays.

3.5 Advanced Standing

Students registering for courses at UOWD may apply for advanced standing (specified credit, or exemption) on the basis of tertiary studies satisfactorily completed at other approved universities or colleges of advanced education, or at other approved tertiary educational institutions, prior to their enrolment at UOWD. For more information, students can refer to the Advanced Standing Policy on the MyUOWD website.

3.6 Enrolment using Student On-Line System (SOLS)

As a student of the UOWD you are provided with access to the Student On-Line System (SOLS). It is a vital tool in the management of your enrolment at the University. It provides you with a range of services including subject enrolment and withdrawal, exam marks, personal details and a range of other services.

How to access SOLS

All students are provided with what is known as a UNIX login and password when they commence their degree program. The login consists of the student's initials and a random number. The password consists of randomly generated characters. The password can be changed by visiting www.uow.edu.au/student/it/myaccount (see "Managing your Password"). Students must use the UNIX login and password to access SOLS, which is available at my.uowdubai.ac.ae. In case of problems with the login and password for SOLS, students must contact the ITTS Office (block 5).

Re-enrolling (current) students are responsible for enrolling themselves using SOLS and maintaining an accurate enrolment record so that results can be properly declared at the end of session. If a subject you are trying to enroll in is full, an electronic Manual Enrolment form can be submitted online for approval. Please note that approval for manual enrolment is not granted automatically.

To complete the "electronic" manual enrolment process, students must do the following:

1. Check for notices online regarding quota increases.
2. If there are no expected quota increases then submit the form online after date specified in the notice.
3. You will receive an email on your SOLS account within 5 working days regarding the status of your application.

3.7 SOLSMail (available through SOLS)

To ensure that all communications with students are conducted in the most secure, reliable and efficient manner, the University has designed a system where official communications between the University and students are sent on-line as messages to the SOLSMail and generally NOT BY POST (although this may be utilized on occasions).

SOLSMail is the primary method for communication with students. University Policy requires students to check their SOLSMail at least once per week during each semester. SOLSMail is an "Electronic Letterbox" to which all official communications will be sent.

SOLSMail should not be confused with e-mail. They are not the same and they work in very different ways. Using SOLSMail rather than e-mail provides the University with the ability to check that each official communication, such as a fee notice, has been delivered to and read by the student. This ability to track or check notifications is beneficial because it ensures that important official messages sent to students do not go astray.

3.8 Pre-Requisites

A system of pre-requisite subjects operates to ensure students are adequately prepared for any particular subject. Some subjects have a pre-requisite subject. A subject which has a pre-requisite cannot be taken unless the pre-requisite subject has been successfully completed. If the pre-requisite is not completed, the enrolment will initially be shown as "Provisional" on the student's SOLS record, and the student will subsequently be automatically withdrawn (removed) from the subject. In special circumstances the Dean may approve the pre-requisite to be taken as a co-requisite.

3.9 Exclusions

If a subject has an exclusion clause to it, students should not enrol in its equivalent. If students complete both subjects, **only one** will be counted towards graduation requirements. For example, TBS901 has an exclusion of TBS980 and vice-versa. If a student enrolls and successfully completes both TBS901 and TBS980, only one of the two subjects will be counted. The full list of subject exclusions is shown below.



SUBJECT EXCLUSIONS LIST	
Students who have completed	Should not enrol in
ENGG 954	MGMT 910
ENGG 954	TBS 921
MARK 922	TBS 904
MGMT 910	ENGG 954
MGMT 910	TBS 921
TBS 901	TBS 980
TBS 903	TBS 981
TBS 904	MARK 922
TBS 920	TBS 984
TBS 921	ENGG 954
TBS 921	MGMT 910
TBS 980	TBS 901
TBS 981	TBS 903
TBS 984	TBS 920

3.10 Variations to Enrolment

Variation to Degree Enrolment

After consultation with an Academic Advisor, a student may apply to the Dean for permission to change their enrolment from one degree program to another (e.g. from the MBA to MIB). Permission to change a program enrolment is contingent upon any restrictions that may be imposed, and on the number of students to be registered for a particular course. If the change is approved, the student becomes subject to the Rules relating to the new degree program. Except with approval to the contrary, restrictions imposed on enrolment of a student prior to, or at the time of variation of enrolment, shall continue to apply after the change.

Students who are changing their enrolment from one degree program to another may not receive credits for subjects that they have already completed if these subjects are not on the approved list for the new program that they have transferred to. Therefore it is very important for students who wish to change their degree program to meet with the Academic Advisor in order to determine which subjects are eligible for transfer and which additional subjects need to be completed.

Variation to Subject Enrolment

A student may withdraw from a subject provided such withdrawal is made by the date specified in Section 2.1 of this Degree Planner. A student who wishes to withdraw from one or more subjects is advised to seek advice from an Academic Advisor before doing so. There are three key withdrawal dates in each session. These are:

- The last day to withdraw from a subject without financial penalty
- The last day to withdraw from a subject and be eligible for a 75% refund OR an 80% transfer of fees (please contact the Cashier for further information as restrictions may apply)
- The last date to withdraw from a subject without academic penalty

Please Note: The dates of withdrawal from subjects will have an impact on a student's entitlement to fee refunds or fee transfers. Please refer to the Fees Policy available on the MyUOWD website under the "Policies" link.

A student can withdraw from a subject in either of the following ways:

- Online via SOLS, or
- A Special Consideration form can be completed to withdraw from the subject after the last day to withdraw. The form and supporting evidence should be submitted to the Faculty Office (see Special Consideration Policy) and is subject to approval.

Where a variation is a withdrawal, and is made no later than the last day for withdrawal (see Section 2.1 Session Dates), the student shall be deemed to have not enrolled in that subject, and that subject will then not appear on their academic record.

Late withdrawal

Where a variation is a withdrawal, and is made later than the last day for withdrawal (see Section 2.1 Academic Calendar Dates), the student shall be deemed to have enrolled in that subject, and that subject will then appear on their academic record. Exceptions to this rule may only be approved if the student has acceptable medical or personal reasons. An application (supported by documentary evidence) may be made under the University's Special Consideration Policy for 'late withdrawal from a subject without academic penalty'.

If a student's application for special consideration to withdraw from a subject is approved, the student will be deemed to have withdrawn from the subject without penalty and "Withdrawn late with approval" will appear against the subject on the academic record of the student. If a student's application for special consideration is not approved, the student's enrolment will stand and a grade will be declared for that subject.

Request to Enrol in Additional Subjects

After consultation with an Academic Advisor, a student may apply to the Dean for permission to enrol in an additional subject. Permission for a student to enrol in an additional subject is contingent upon restrictions imposed by relevant provisions of the Rules of each program.

3.11 Minimum Passing Requirements

The approved grades of performance and associated ranges of marks for postgraduate subjects are:

High Distinction (HD)	85 to 100%
Distinction (D)	75 to 84%
Credit (C)	65 to 74%
Pass (P)	50 to 64%
Fail (F)	0 to 49%
Technical Fail (TF)	

In order to pass a subject, students **must pass the Final Examination** as per the Subject Outline. This is irrespective of a student's other marks during the session. Students who obtain a composite (aggregate) mark of greater than 50% but do not satisfy the Final Examination pass requirements will be awarded a "Technical Fail" grade.

Students must also 'reasonably' complete all of the other assessment tasks (other than the Final Examination) in order to pass the subject. 'Reasonable' completion of an assessment task will be determined based on the instructions given to the student including: word length, demonstration of research and analysis where required, the Plagiarism Policy, and completion of each section/component of the assessment. Failure to 'reasonably' complete any assessment tasks to the standard specified above will result in a Fail grade awarded for the subject.

3.12 Minimum Rate of Progress (MRP)

In accordance with the Assessment Policy, a student enrolled in a postgraduate program is required to maintain a minimum rate of academic progress.

- Where a student fails to meet the MRP requirements in the first instance, he/she will be placed on 'Probation' status. **Probation** is when students obtain a score of < 50 or a Technical Fail in one subject.
- **Exclusion** from program is when student receives a score of < 50 in more than one subject or in any of the semesters following **Probation**.

For full details regarding the minimum rate of progress as specified in the Assessment Policy, please refer to the "Policies" section on the MyUOWD website.

3.13 Special Consideration

Under exceptional circumstances, such as the student suffering from **SERIOUS** illness or other circumstances beyond his/her control, the student may apply for special consideration, including supplementary assessment for internal continuous assessment tasks. Students must provide all of the required information to support their application (including, but not limited to, a medical certificate, medical records, and a specific report from the doctor, as per the requirements of the Special Consideration policy). The Special Consideration policy is summarized in subject outlines and available on the "Policies" section of the MyUOWD website.

Special consideration requests for assessments during the session (e.g. assignments, tests, quizzes, etc.) must be submitted to the lecturer within 5 working days from the due date. Special consideration requests for Final Exams must be submitted to the Dean by completing the relevant form and attaching evidence, within 5 working days from the Final Exam date. Students who miss the Final Exam and are given permission under the Special Consideration Policy to sit for a Supplementary Final Exam should note that they may miss enrolment, graduation and other deadlines which are set based on the regular Final Exam dates.

Please note that applying for special consideration does not automatically mean that the request will be granted. Special consideration will only be approved in the case of **SERIOUS** illness or exceptional circumstances. Medical certificates must provide detailed information about the illness (and be supported by additional evidence, if applicable). Medical certificates stating illnesses such as URTI, cold, stomach ache, back ache, etc. are normally rejected. Previous requests for special consideration by the student are also taken into consideration when making a decision about the request outcome.

If a student's supplementary Final Exam request is approved, he/she must be available to sit for the exam on the specified date. No alternative arrangements will be made. The student is also required to pay the supplementary Final Exam fee prior to taking the exam.

3.14 Release of Final Results

Declaration of results

In accordance with the University's Assessment Policy a mark and an approved grade of performance is determined and declared for each subject in which a student is enrolled. An Assessment Committee meeting (ACM) is held after each exam session in order to declare the results for all the subjects in the session. The ACM follows specific processes, set out in the respective terms of reference. The ACM is generally scheduled within 12 days from the date of the last final exam.

Release of results

After final results are declared at the ACM, they are released and made available on the Student On-Line Services (SOLS) system only. No information concerning results will be given by telephone or via email. Students must log in to their SOLS account and check their final results.

Withheld results

A withheld (WH) result may be granted in the following circumstances:

- On the basis of medical, compassionate or other circumstances under the Special Consideration Policy;
- Where there are unavoidable delays in assessing the material or where the student is being investigated by the Disciplinary Committee.

Where a “withheld” result is granted, it is the student's responsibility to contact the Faculty Office as soon as practicable. Failure to do so may result in a “Fail” grade being determined. For detailed information, see Assessment Policy.

3.15 Re-Evaluation Requests

If a student believes that a mark (or grade) they have been awarded for a subject is not indicative of their performance or that there may have been an error in determining the mark, he/she should approach the lecturer concerned in the first instance to discuss the matter.

Subsequent to discussions with the lecturer, if the student still believes the mark is not correct, he/she may submit a formal re-evaluation request to the Faculty Office by completing the “Request for Re-Evaluation/Re-Marking of Examination” form. This form may be downloaded from the MyUOWD website. An administrative fee of AED 200 per subject is applicable in this instance. Applications to the Faculty Office should be made **no later than 10 working days** after the release of the final results.

If a student is still not satisfied with the outcome following the formal re-evaluation, he/she may appeal to the Vice President (Academic) of UOWD outlining his/her concern and stating reasons, accompanied by full documentary evidence. The Vice President (Academic) will consider the request and may investigate and make a ruling.

3.16 Graduation Requirement: WAM of 60

To complete their degree and graduate, ALL PG students must achieve a minimum overall Weighted Average Mark (WAM) of 60. Students who do not achieve a WAM of 60 or more, will not be eligible to graduate and must complete additional subjects.

3.17 Application for Graduation

Students who complete all of the requirements for their degree are eligible to graduate at the next appropriate graduation ceremony. Students who believe they are eligible to graduate are required to lodge a “Graduation Application” form, so that their graduation eligibility can be determined and accepted by the Graduation Committee. The Graduation Committee meets five times per year. Graduation Application Forms must be lodged at the Registrar's Office at UOWD by the relevant deadline.

Upon the Graduation Committee accepting, verifying and approving that a student has met the required criteria to be eligible to graduate and receive their testamur, UOWD will confirm with the student that they are indeed eligible to graduate.

3.18 Graduation with Distinction

In order to graduate "with Distinction", students must gain a Weighted Average Mark of 75 or more in the subjects that comprised their course. All subjects which constitute the degree program will be taken into account in determining the granting of an award "with Distinction". Where students have been granted advanced standing towards their degree or diploma as a result of studies undertaken elsewhere, only their performance in subjects studied at UOWD will be taken into account in determining whether they qualify for graduation with distinction. View the Assessment Policy for more details.

3.19 Academic Misconduct

Students are warned that academic misconduct (for example, cheating or copying in examinations or assignments) will have serious consequences. Cheating in any part of a subject may result in failure in the whole subject. Cheating in examinations or deliberate plagiarism in assignments can result in expulsion from the University.

3.20 Amendment of Academic Record

Circumstances where an academic record may be amended

There are only three circumstances where a student's academic record may be amended, that is, where:

- (a) there has been an error in enrolment;
- (b) a student has successfully applied under the Student Academic Grievance Policy to have a mark or grade altered; or
- (c) a student has successfully applied for special consideration under the Special Consideration Policy that has resulted in changing a final grade to withdrawn.

Detailed information is available in the Assessment Policy

3.21 Leave of Absence

Students become eligible for leave of absence at the beginning of the second semester of enrolment and may take a leave of absence for up to one year provided that they apply to the Registrar before the semester for which leave is requested. The Leave of Absence request form is available at MyUOWD.

3.22 Transfer to UOW campus Australia

Candidates may transfer to the main campus of the University of Wollongong in Australia **with a minimum of 3 subjects remaining**, subject to meeting Australian Government visa requirements. All marks and grades are fully transferable for relevant subjects. Information regarding Transfer can be made at the Registrars Department.

3.23 Articulation: Completing another UOWD Masters

For students who have satisfactorily completed a master's degree program at UOWD, articulation to other postgraduate programs is possible, with some advanced standing granted. Students must meet with their academic advisor to ensure they complete relevant subjects and are eligible to graduate. Please refer to the "Policies" section on the MyUOWD website for the Articulation Table <https://my.uowdubai.ac.ae/policies/index.php>



FACULTY STAFF INFORMATION

FACULTY OF BUSINESS & MANAGEMENT STAFF

NAME	QUALIFICATIONS
Dr Laubie Li - Dean	PhD UNSW
Dr Robert Pech Assistant Professor	PhD RMIT Australia
Dr. Melodena Balakrishnan Associate Professor	BSc Bombay University, MBA Pune, PhD India, Pune, India
Dr Prakash Vel Kumar Shankar Associate Professor	BBA, MPhil, MBA, PhD Madurai Kamaraj University
Dr Ravindra Saxena Assistant Professor	BSc. MA, PhD University of Kanpur
Dr. Arijit Sikdar Associate Professor	BTech Indian School of Mines, Dhanbad, India PhD Indian Institute of Management, Ahmedabad
Dr P Jayashree Associate Professor & Head, CASPD	MA Psychology, BA (Hons) Psychology, PhD University of Delhi
Dr Jawahitha Sarabdeen Associate Professor	LLB, MCL International Islamic University, PhD Multimedia University, Malaysia
Dr. Swapna Koshy, Assistant Professor	BA Kerala, MA Kerala, TESOL Cambridge, PhD Kerala
Dr Mike Newnham Assistant Professor	PhD University of Leicester, UK
Dr Balan Sundarakani Associate Professor	BEgg, MEgg, PhD Indian Institute of Technology
Dr Slim Siadi, Assistant Professor	PhD Polytechnic School Montreal, Canada
Dr. Ahmed Abdel Moneim Associate Professor	BSc (Hons) Helwan; MSc Coventry; Postgraduate Diploma in Management of Manufacture Coventry University
Dr Kathy Shen, Associate Professor	BS, MS Peking University; MPhil, PhD City University Hong Kong
Dr Mona Moussa, Assistant Professor	PhD in Psychology
Dr. Michael Willemyns Associate Professor	BA (Hons.) First Class U.Qld, PhD U.Qld
Dr.Ritu Seghal, Assistant Professor	PhD University of Delhi
Dr Valerie Lindsay Associate Professor	PhD University of Warwick, UK
Dr Michael Glykus Associate Professor	PhD Wolfson College- Cambridge university, UK

FACULTY OF FINANCE & ACCOUNTING STAFF

NAME	QUALIFICATIONS
Prof. David Goodwin – Dean	BBS; MBA University of Otago; PhD University of Adelaide
Dr Mufeed Rawashdeh Associate Professor	PhD, St Louis University, USA MBA, St Louis University, USA
Dr. Naeem Muhammad Associate Professor	BSc, MSc University of Karachi, MA, PhD Simon Fraser University
Dr. Munir M Lutfi Assistant Professor	BA Jordan, MSc George Washington, PhD Glasgow
Dr. Gwendolyn Rodrigues Associate Professor	BA, MA Economics, Dip. Research Methodology Tata Institute of Social Science, PhD Mumbai University
Dr Asima Shirazi Assistant Professor	PhD SZABIST Karachi, BSc (Hons) Brunel, MLit Aberdeen
Dr Ramzi Nekhilli Associate Professor	BSc SFax, MSc – Institut Supérieur de Gestion, PhD Business Administration
Dr Hela Miniaoui Assistant Professor	MA Economics, University of Laval, Quebec; PhD (Economics) University of Tunis
Dr Leoni Jooste Assistant Professor	PhD, Financial Accounting, University of Pretoria
Mrs Nandini Kaul Instructor	BA Economics (Hons) Delhi, BEd Delhi, MA Economics Delhi
Dr Ali Saedvandi Assistant Professor	PhD Economics, Tarbiat Modares University
Dr Scott Fargher Assistant Professor	PhD in Labour Economics, University of Edinburgh
Dr Lamia Obay Assistant Professor	PhD in International Finance & Banking, The George Washington University, USA
Dr Dadakas Dimitrios Assistant Professor	PhD in Economics, University of Madedonia

FACULTY OF ARTS AND HUMANITIES

Dr. Feras Hamza	PhD Oxford - SOAS
Dr. Sreya Mitra	PhD Wisconsin
Prof. Alma Kadragic	PhD English Literature – City University of New York



FACULTY OF COMPUTER SCIENCE & ENGINEERING STAFF

Dr. Mohamed-Salem Mohamed Vall DEAN Associate Professor	BSc Jeddah, MSc, PhD Montreal
Mr. Nawar Al Hakeem Associate Dean Associate Professor	BEng, Syracuse, MBA Wollongong
Dr. Farhad Oroumchian Associate Professor	BSc Shahid Beheshti, MSc Sharif, PhD Syracuse
Dr. Abdellatif Tchanchane Associate Professor	BSc Case Western Reserve University, MA Arizona State University, PhD Setif University
Dr. Halim M. Khelalfa Associate Professor	Ingeniorat Algiers, MS American University, PhD Illinois Institute of Technology
Dr Kamal Jaafar Associate Professor	BSc, MBA, PhD Cambridge University
Dr Mohamed Watfa Associate Professor	PhD, University of Oklahoma, USA
Dr Nidhal Abdulaziz Associate Professor	BSc Eng Basrah University, MSc Eng Basrah University, PhD Elect Eng Monash University Australia,
Dr. Catherine Todd Assistant Professor	BEng (Hons) UOW, PhD UOW
Dr Soly Mathew Biju Assistant Professor	BCompSci, MA, PhD Banasthali University
Pauline Fortes Teaching Assistant	BS Applied Mathematics, MS Applied Mathematics
Ms Zeenath Khan Instructor	BCompSci, MIB, UOWD

PROGRAM INFORMATION

4.1 Master of Business Administration

<i>Testamur Title of Degree:</i>	Master of Business Administration
<i>Abbreviation:</i>	MBA
<i>Home Faculty:</i>	Faculty of Business & Management
<i>Duration:</i>	2 years (6 Sessions) full time or part time equivalent.
<i>Total Credit Points:</i>	72
<i>Starting Session(s):</i>	Intakes each session (Autumn, Spring, Summer).
<i>Delivery Mode:</i>	Face to Face
<i>Location:</i>	University of Wollongong in Dubai, Knowledge Village.
<i>Timing/Attendance:</i>	6:00pm – 9:00pm Saturday to Thursday.

Overview

The Master of Business Administration (MBA) is intended for people who require the knowledge, competencies and managerial skills necessary to operate in a challenging and global environment.

The compulsory subjects of the program have a strategic focus that tackle practical issues and concepts and develop skills required by a modern manager. At the completion of the MBA program, graduates should be able to analyze any problem they encounter within an organization by identifying the key factors, generating a range of solutions and make strong managerial decisions.

The compulsory subjects offer an introduction to key managerial concepts and the skills required by managers, providing a foundation for the elective subjects that follow.

The MBA is an interdisciplinary and practical course that allows participants to apply knowledge gained from their study to bridge the gap between classroom learning and the business world. The program of study requires a commitment to teamwork and enthusiasm to achieve. The University of Wollongong in Dubai has received Accreditation from the UAE Ministry of Education for all their postgraduate programs.

There are nine (9) compulsory subjects that are required to be completed along with three (3) elective subjects to be selected from the approved subjects provided each session.

Course Program

MBA Core (9 Subjects)	
TBS 901	Accounting for Managers
TBS 902	Statistics for Decision Making
TBS 903	Managing People in Organizations
TBS 904	Marketing Management
TBS 905	Economic Analysis of Business
TBS 907*	Financial Strategy
TBS 909	Corporate Governance
TBS 920	International Business Strategy
TBS 921*	Strategic Decision Making

The **three (3) elective subjects** (18cp) will be chosen from the list below. The electives can be from across the streams or within a stream. Each subject is 6 Credits unless mentioned differently. Please note these electives offered are subject to change.

Elective Streams		
Finance (prerequisite: TBS 907)	FIN924	Advanced Financial Statement Analysis
	FIN930	Islamic Banking
	FIN 922	Advanced Investment Analysis
	FIN955	International Banking
HR (Prerequisite TBS 903)	MGMT908	Human Resource Development
	MGMT915	Management of Change
	MGMT953	Human Resource Management
	MGMT978	Cross Cultural Management
Marketing (Prerequisite TBS 904)	MARK917	Business to Business Marketing
	MARK936	Consumer Behaviour
	MARK940	Marketing Communications
	TBS982	Marketing in a Global Economy
	MARK 938	Services and Relationship Marketing
Project Management (Prerequisite TBS902)	ENGG951	Engineering Project Management
	IACT901	IT strategic Planning
	MGMT915	Management of Change
	TBS930	Operations Management
Information Systems	CSCI925	Human Computer Interaction
	IACT901	IT Strategic Planning
	IACT906	Business On Line
	IACT918	Corporate Network Planning
Logistics and Supply Chain Management (Prerequisite TBS 902)	ENGG939	Engineering Logistics
	TBS908	Supply Chain Management
	TBS925	Inventory Management
	TBS928	Logistics System Management
	TBS934	Logistics Information Systems



Quality	MGMT915	Management of Change
	TBS950	Quality in Management
	TBS953	Management in Service Quality
Other Electives	TBS 906	Information Technology
	TBS923	Current Issues in Business
	TBS922	Management Project
	TBS924	Management Project (12 credits)

- * TBS 901 is a pre-requisite for TBS907 and needs to be completed before taking TBS907
- * **Capstone Subject TBS921 to be taken in the final semester**

It is highly recommended to complete TBS920 after completion of TBS903, TBS901, TBS904 and TBS905.

Recommended sequence of study for students joining in Autumn semester :

Autumn	Spring	Summer	Autumn	Spring	Summer
TBS 901	TBS 902	TBS 905	TBS 907	TBS 920	TBS 921
TBS 903	TBS 904	TBS 909	Elective	Elective	Elective

Recommended sequence of study for students joining in Spring semester :

Spring	Summer	Autumn	Spring	Summer	Autumn
TBS 901	TBS 902	TBS 905	TBS 907	TBS 920	TBS 921
TBS 903	TBS 904	TBS 909	Elective	Elective	Elective

Recommended sequence of study for students joining in Summer semester :

Summer	Autumn	Spring	Summer	Autumn	Spring
TBS 901	TBS 909	TBS 905	TBS 907	TBS 920	TBS 921
TBS 903	TBS 904	TBS 902	Elective	Elective	Elective

- Students are strongly encouraged to follow the subject sequence to graduate in a timely manner.
- All subjects are not offered in all semesters and if the sequence is not followed, they run a risk of a delay in their graduation.
- If a student fails a subject, he/she needs to repeat the subject at the session it is scheduled for.
- The University has no obligation to offer a subject to meet the requirements of an individual student.

It is the responsibility of the students to check the subject offering in order to plan their degree.

4.2 Master of International Business

<i>Testamur Title of Degree:</i>	Master of International Business.
<i>Abbreviation:</i>	MIB
<i>Home Faculty:</i>	Faculty of Business & Management
<i>Duration:</i>	2 years (5 Sessions) full time or part time equivalent.
<i>Total Credit Points:</i>	60
<i>Starting Session(s):</i>	Intakes each session (Autumn, Spring, Summer).
<i>Delivery Mode:</i>	Face to Face
<i>Location:</i>	University of Wollongong in Dubai, Knowledge Village.
<i>Timing/Attendance:</i>	6:00pm – 9:00pm Saturday to Thursday.

Overview

The Master of International Business (MIB) is intended for both new graduates about to embark on their first line managerial position, and as well for experienced managers with relevant professional experience who wish to enhance their knowledge and expertise in global management issues.

The MIB attempts to provide candidates with the necessary skills and competencies to manage effectively in a challenging and changing global environment, and attempts to prepare graduates for careers in management positions in both the public and private sectors.

Course Requirements

Candidates are required to complete ten (10) subjects (60cps) according to the sequence of study listed below.

There are five (7) compulsory subjects that are required to be completed along with three (3) elective subjects to be selected from the approved subjects provided each session.

Course Program

MIB Core (7 Subjects)		MIB Electives (Choose any 3)	
TBS980	International Financial Management	ECON939	Quantitative Economic Analysis
TBS981	Managing in Multi-National Companies	FIN928	Multinational Financial Management
TBS982	Marketing in a Global Economy	FIN955	International Banking
MGMT978	Cross Cultural Management	MARK977	Research for Marketing Decisions
TBS983	International Business Environment	MGMT915	Management of Change
TBS923	Current Issues in International Business	MGMT953	Human Resource Management
*TBS984	International Business	TBS904	Marketing Management
		TBS905	Economic Analysis of Business
		TBS906	Information Systems for Managers
		TBS908	Supply Chain Management
		TBS930	Operations Management

* Capstone Subject TBS984 to be taken in the final semester

Recommended sequence of study for students joining in Autumn semester :

Autumn	Spring	Summer	Autumn	Spring
TBS980	TBS982	TBS983	TBS 923	TBS984
TBS981	MGMT978	Elective	Elective	Elective

Recommended sequence of study for students joining in Spring semester :

Spring	Summer	Autumn	Spring	Summer
TBS980	TBS982	TBS983	TBS 923	TBS984
TBS981	Elective	MGMT978	Elective	Elective

Recommended sequence of study for students joining in Summer semester :

Summer	Autumn	Spring	Summer	Autumn
TBS980	TBS982	TBS 923	TBS983	TBS984
Elective	MGMT978	TBS981	Elective	Elective

- Students are strongly encouraged to follow the subject sequence to graduate in a timely manner.
- All subjects are not offered in all semesters and if the sequence is not followed, they run a risk of a delay in their graduation.
- If a student fails a subject, he/she needs to repeat the subject at the session it is scheduled for.
- The University has no obligation to offer a subject to meet the requirements of an individual student.

It is the responsibility of the students to check the subject offering in order to plan their degree.

4.3 Master of Quality Management

<i>Testamur Title of Degree:</i>	Master of Quality Management.
<i>Abbreviation:</i>	MQM
<i>Home Faculty:</i>	Faculty of Business and Management
<i>Duration:</i>	1.5 years (4 Sessions) full time or part time equivalent.
<i>Total Credit Points:</i>	48
<i>Starting Session(s):</i>	Intakes each session (Autumn, Spring, Summer)
<i>Delivery Mode:</i>	Face to Face
<i>Location:</i>	University of Wollongong in Dubai, Knowledge Village.
<i>Timing/Attendance:</i>	6:00pm – 9:00pm Saturday to Thursday.

Overview

The Master of Quality Management (MQM) was introduced in Dubai in 1996 in association with the Dubai Quality Group. It is the study of modern management and productivity improvement concepts and techniques. A drive for improved quality requires a change in the whole company culture, including increased quality control from both internal and external sources.

This degree is designed to equip decision-makers and managers with the tools necessary to implement and manage quality systems within organizations.

Course Requirements

Students are required to complete eight (8) subjects (48cps) according to the sequence of study listed below. There are five (5) compulsory subjects that are required to be completed along with three (3) elective subjects to be selected from the approved subjects provided each session.

Course Program

MQM Core (5 Subjects)		MQM Electives (any 3)	
TBS 950	Quality in Management	ECON 939	Quantitative Economic Analysis
TBS 951	Statistics for Quality Management	FIN 955	International Banking
TBS 952*	Implementing Quality Systems	MARK 977	Research for Marketing Decisions
TBS 953*	Management of Service Quality	MGMT 915	Management of Change
TBS 955*	Quality Assurance	MGMT 953	Human Resource Management
		MGMT 978	Cross Cultural Management
		TBS 901	Accounting for Managers
		TBS 904	Marketing Management
		TBS 905	Economic Analysis of Business
		TBS 906	Information Systems for Managers
		TBS 908	Supply Chain Management
		TBS 930	Operations Management
		TBS 981	Managing in Multi-National Companies
		TBS 982	Marketing in a Global Economy
		TBS 983	International Business Environment
		TBS 984	International Business

* TBS 950 is a pre-requisite for TBS952 & TBS953 and needs to be completed before taking those subjects

* Capstone Subject TBS955 to be taken in the final semester

Recommended sequence of study for students joining in Autumn semester

Autumn	Spring	Summer	Autumn
TBS950	TBS953	TBS952	TBS955
TBS951	Elective	Elective	Elective

Recommended sequence of study for students joining in Spring semester

Spring	Summer	Autumn	Spring
TBS950	TBS952	TBS953	Elective
TBS951	Elective	TBS955	Elective

Recommended sequence of study for students joining in Summer semester

Summer	Autumn	Spring	Summer
TBS950	TBS953	TBS952	TBS955
Elective	TBS951	Elective	Elective

- Students are strongly encouraged to follow the subject sequence to graduate in a timely manner.
- All subjects are not offered in all semesters and if the sequence is not followed, they run a risk of a delay in their graduation.
- If a student fails a subject, he/she needs to repeat the subject at the session it is scheduled for.
- The University has no obligation to offer a subject to meet the requirements of an individual student.

It is the responsibility of the students to check the subject offering in order to plan their degree.

4.4 Master of Strategic Marketing

<i>Testamur Title of Degree:</i>	Master of Strategic Marketing.
<i>Abbreviation:</i>	MSM
<i>Home Faculty:</i>	Faculty of Business and Management
<i>Duration:</i>	1.5 years (4 Sessions) full time or part time equivalent.
<i>Total Credit Points:</i>	48
<i>Starting Session(s):</i>	Intakes each session (Autumn, Spring, Summer).
<i>Delivery Mode:</i>	Face to Face
<i>Location:</i>	University of Wollongong in Dubai, Knowledge Village.
<i>Timing/Attendance:</i>	6:00pm – 9:00pm Saturday to Thursday.

Overview

The MSM Program provides students with the advanced skills to generate products and services for which there is a defined customer need, and to strategically position the product or service in the market with effective promotion, pricing and distribution strategies. The program strives to provide students with a thorough grounding in the strategic marketing techniques required to excel in today's increasingly competitive global marketplace.

The MSM is for marketing practitioners, with the ambition to become effective marketing strategists, who will apply contemporary marketing theory and practice, incorporating international and global perspectives, to their current and future roles. The knowledge, competencies and skills required in modern day marketing are developed through applied research and critical synthesis of alternate marketing perspectives. The MSM provides opportunities for students to build a solid base for continuous self-development as a marketing expert in their field of specialization.

Course Requirements

Candidates are required to complete eight (8) subjects (48cps) according to the sequence of study listed below.

There are six (6) compulsory subjects that are required to be completed along with two (2) elective subjects to be selected from the approved subjects provided each session.

Course Program

MSM Core (6 Subjects)		MSM Electives (any 2)	
MARK 922	Marketing Management	MARK 917	Business to Business Marketing
MARK 936	Consumer Behaviour	MARK 938	Managing Services & Relationship Marketing
MARK 940*	Marketing Communications	MARK 959	Sales Management
MARK 977	Research for Marketing Decisions	TBS 901	Accounting for Managers
MARK 997	Retail Marketing Management	TBS 903	Managing People in Organizations
MARK 935*	Marketing Strategy	TBS 905	Economic Analysis of Business
		TBS 906	Information Systems for Managers
		TBS 920	International Business Strategy

* MARK936 is a pre-requisite for MARK940 and needs completion before taking MARK940

* **Capstone Subject MARK935 to be taken in the final semester**

Recommended sequence of study for students joining in Autumn semester

Autumn	Spring	Summer	Autumn
MARK922	MARK940	MARK977	MARK935
MARK936	MARK997	Elective	Elective

Recommended sequence of study for students joining in Spring semester

Spring	Summer	Autumn	Spring
MARK922	MARK977	MARK940	MARK935
MARK936	MARK997	Elective	Elective

Recommended sequence of study for students joining in Summer semester

Summer	Autumn	Spring	Summer
MARK922	MARK940	MARK997	MARK935
MARK936	MARK977	Elective	Elective

- Students are strongly encouraged to follow the subject sequence to graduate in a timely manner.
- All subjects are not offered in all semesters and if the sequence is not followed, they run a risk of a delay in their graduation.
- If a student fails a subject, he/she needs to repeat the subject at the session it is scheduled for.
- The University has no obligation to offer a subject to meet the requirements of an individual student.

It is the responsibility of the students to check the subject offering in order to plan their degree.

4.5 Master of Strategic Human Resource Management

<i>Testamur Title of Degree:</i>	Master of Strategic Human Resource Management.
<i>Abbreviation:</i>	MSHRM
<i>Home Faculty:</i>	Faculty of Business and Management
<i>Duration:</i>	1.5 years (4 Sessions) full time or part time equivalent.
<i>Total Credit Points:</i>	48
<i>Starting Session(s):</i>	Intakes each session (Autumn, Spring, Summer).
<i>Delivery Mode:</i>	Face to Face
<i>Location:</i>	University of Wollongong in Dubai, Knowledge Village.
<i>Timing/Attendance:</i>	6:00pm – 9:00pm Saturday to Thursday.

Overview

The Master of Strategic Human Resource Management (MSHRM) is designed to prepare students and professionals with advanced human resource management skills. The program presents powerful tools for analyzing strategic alignment, managing employment relationships and identifying leadership and team dynamic skills essential to orchestrate organizational change. The program will provide critical perspectives on the role and functions of HR executives and change agents.

All courses in the MSHRM degree program are designed to equip individuals with the management expertise to identify and provide solutions to human resource issues that are complex and evolving. Strategic human resource management will provide graduates with the opportunity to obtain proficiency in human resource management concepts, skills and activities in order to help develop human resource systems that will support an organization's strategic objectives.

Course Requirements

Candidates are required to complete eight (8) subjects (48cps) according to the sequence of study listed below.

There are six (6) compulsory subjects that are required to be completed along with two (2) elective subjects to be selected from the approved subjects provided each session.

Course Program

Core (6 Subjects)		Electives (Choose any 2)	
TBS903	Managing People in Organisations	MARK922	Marketing Management
MGMT908	Human Resource Development	MGMT910	Strategic Management
MGMT920	Organisational Analysis	MGMT915	Management of Change
MGMT949	Performance Management	MGMT978	Cross Cultural Management
MGMT969	Job Analysis, Recruitment and Selection		
*MGMT930	Strategic Human Resource Management		

* Capstone Subject MGMT930 to be taken in the final semester

Recommended sequence of study for students joining in Autumn semester

Autumn	Spring	Summer	Autumn
MGMT908	MGMT969	MGMT949	MGMT930
TBS903	MGMT920	Elective	Elective

Recommended sequence of study for students joining in Spring semester

Spring	Summer	Autumn	Spring
MGMT920	MGMT949	MGMT969	MGMT930
TBS903	MGMT908	Elective	Elective

Recommended sequence of study for students joining in Summer semester

Summer	Autumn	Spring	Summer
MGMT908	MGMT969	MGMT949	MGMT930
TBS903	MGMT920	Elective	elective

- Students are strongly encouraged to follow the subject sequence to graduate in a timely manner.
- All subjects are not offered in all semesters and if the sequence is not followed, they run a risk of a delay in their graduation.
- If a student fails a subject, he/she needs to repeat the subject at the session it is scheduled for.
- The University has no obligation to offer a subject to meet the requirements of an individual student.

It is the responsibility of the students to check the subject offering in order to plan their degree.

4.6 Master of Science in Logistics

<i>Testamur Title of Degree:</i>	Master of Science Logistics.
<i>Abbreviation:</i>	MSL
<i>Home Faculty:</i>	Faculty of Business and Management
<i>Duration:</i>	1.5 years (4 Sessions) full time or part time equivalent.
<i>Total Credit Points:</i>	48
<i>Starting Session(s):</i>	Intakes each session (Autumn, Spring, Summer).
<i>Delivery Mode:</i>	Face to Face
<i>Location:</i>	University of Wollongong in Dubai, Knowledge Village.
<i>Timing/Attendance:</i>	6:00pm – 9:00pm Saturday to Thursday.

Overview

The Master of Science Logistics program is designed to provide professionals working within the logistics and operations management area with the skills to manage the flow of materials and information within and between organizations and their business environment. It incorporates both practical and theoretical aspects of logistics and supply chain management to assist managers in increasing business efficiency and advancing their individual careers.

This course will provide managers with the tools to effectively implement supply chain management, enhancing the competitive success and profitability of their organizations. Professionals and managers working within the logistics and operations management area will acquire the skills required to manage the flow of materials and information within and between organizations.

Course Requirements

Candidates are required to complete eight (8) subjects (48cps) according to the sequence of study listed below.

There are six (6) compulsory subjects that are required to be completed along with two (2) elective subjects to be selected from the approved subjects provided each session.

Course Program

Core (6 Subjects)		Electives (Choose any 1 stream)	
TBS908	Supply Chain Management	<i>Supply Chain Management Stream</i>	
TBS912	Quantitative Methods for Decision Making	TBS927	Process and Change Management
TBS928	Logistics System Management	TBS933	Procurement Management
TBS925	Inventory Management		
TBS934	Logistics Information Systems	<i>Operations Stream</i>	
*TBS918	Strategic Supply Chain Management	TBS931	Manufacturing and Operations Strategy
		TBS932	Service Operations Management

* Capstone Subject TBS918 to be taken in the final semester

IMPORTANT:

Please contact your Academic Advisor for the recommended subject sequencing as this may vary for this degree

Course Plan 1:

Recommended sequence of study for students joining in Autumn Semester:

Autumn	Spring	Summer	Autumn
TBS 908	TBS 928	TBS 934	TBS 918
TBS 912	TBS 925	Elective	Elective

Course Plan 2:

Recommended sequence of study for students joining in Spring Semester:

Spring	Summer	Autumn	Spring
TBS 908	TBS 934	TBS 912	TBS 918
TBS 928	TBS 925	Elective	Elective

Course Plan 3:

Recommended sequence of study for students joining in Summer Semester:

Summer	Autumn	Spring	Summer
TBS 908	TBS 912	TBS 928	TBS 918
TBS 934	TBS 925	Elective	Elective

- Students are strongly encouraged to follow the subject sequence as discussed with your Academic Advisor to graduate in a timely manner.
- All subjects are not offered in all semesters and if the sequence is not followed, they run a risk of a delay in their graduation.
- If a student fails a subject, he/she needs to repeat the subject at the session it is scheduled for.
- The University has no obligation to offer a subject to meet the requirements of an individual student.

It is the responsibility of the students to check the subject offering in order to plan their degree.

4.7. Master of Applied Finance & Banking

<i>Testamur Title of Degree:</i>	Master of Applied Finance & Banking
<i>Abbreviation:</i>	MAFB
<i>Home Faculty:</i>	Faculty of Finance & Accounting
<i>Duration:</i>	2 years (5 sessions) full time or part time equivalent.
<i>Total Credit Points:</i>	60
<i>Starting Session(s):</i>	Intakes each session (Autumn, Spring, Summer).
<i>Delivery Mode:</i>	Face to Face
<i>Location:</i>	University of Wollongong in Dubai, Knowledge Village.
<i>Timing/Attendance:</i>	6:00pm – 9:00pm Saturday to Thursday.

Overview

The Master of Applied Finance and Banking (MAFB) is designed to prepare students and professionals with advanced financial management and banking skills. This program incorporates finance strategy with banking theory and aligns its application to practice, with the aim of equipping students with the knowledge and skills required to successfully compete in the job market in the areas of accounting, finance and banking. The curriculum has been specifically developed with an international focus, allowing graduates to seek careers in this sector in any part of the world.

The Master of Applied Finance (Banking) offers a detailed examination of banks and related financial intermediaries. It provides an in-depth understanding of banking and finance issues such as investment management, analysis and strategy, international banking management (practice, lending and securities), quantitative economic analysis financial management, and risk assessment. The degree prepares students to develop and enhance professional careers in the finance and banking sectors in a contemporary globalized economy.

Course Requirements

Candidates are required to complete ten (10) subjects (60cps) according to the sequence of study listed below.

There are eight (8) compulsory subjects that are required to be completed along with two (2) elective subjects to be selected from the approved subjects provided each session.

Course Program

MAFB Core (8 Subjects)		MAFB Electives (Any 2)	
ECON 939	Quantitative Economic Analysis	FIN 924	Financial Statement Analysis for Buss.
FIN 922	Investment Management	FIN 926	Advanced Managerial Finance
TBS 905	Economic Analysis of Business	TBS 903	Managing People in Organisations
FIN 925	Banking Theory and Practice	TBS 904	Marketing Management
FIN 928	Multinational Financial Management	TBS 920	International Business Strategy
FIN 955	International Banking		
FIN 956	Bank Lending and Securities		
FIN 923*	Portfolio Management		

* Capstone Subject FIN923 to be taken in the final semester

Recommended sequence of study for students joining in Autumn semester

Autumn	Spring	Summer	Autumn	Spring
FIN956	ECON939	FIN955	FIN922	FIN923
TBS905	FIN925	FIN928	Elective	Elective

Recommended sequence of study for students joining in Spring semester

Spring	Summer	Autumn	Spring	Summer
FIN925	ECON939	FIN922	FIN928	FIN923
TBS905	FIN955	FIN956	Elective	Elective

Recommended sequence of study for students joining in Summer semester

Summer	Autumn	Spring	Summer	Autumn
FIN955	ECON939	FIN925	FIN922	FIN923
TBS905	FIN956	FIN928	Elective	Elective

- Students are strongly encouraged to follow the subject sequence to graduate in a timely manner.
- All subjects are not offered in all semesters and if the sequence is not followed, they run a risk of a delay in their graduation.
- If a student fails a subject, he/she needs to repeat the subject at the session it is scheduled for.
- The University has no obligation to offer a subject to meet the requirements of an individual student.

It is the responsibility of the students to check the subject offering in order to plan their degree.

4.8 Master of Engineering Management

<i>Testamur Title of Degree:</i>	Master of Engineering Management
<i>Abbreviation:</i>	MEM
<i>Home Faculty:</i>	Faculty of Computer Science & Engineering
<i>Duration:</i>	2 years (5 sessions) full time or part time equivalent.
<i>Total Credit Points:</i>	60
<i>Starting Session(s):</i>	Intakes each session (Autumn, Spring, Summer).
<i>Delivery Mode:</i>	Face to Face
<i>Location:</i>	University of Wollongong in Dubai, Knowledge Village.
<i>Timing/Attendance:</i>	6:00pm – 9:00pm Saturday to Thursday.

Overview

The Master of Engineering Management degree program (MEM) is designed to prepare engineers in better management of company resources towards successful completion of engineering projects. Basic management principles are of valid interest for all engineers as involvement in some level of management responsibility is an inevitable component of most engineering careers. The knowledge and skills of integrating engineering and management techniques in designing, operating, evaluating, implementing and managing continuous improvements of systems is highly valued in today's industrial environment.

The Master of Engineering Management is structured so as to enable engineering practitioners to advance into positions of greater managerial responsibility, to advance their careers and to develop core competencies in engineering management. The MEM focuses on the need for students to acquire and demonstrate a command of creative, analytical and conceptual skills. It challenges the student to analyze, diagnose and execute strategic judgments across all engineering functions.

Engineering management prepares individuals to successfully integrate engineering and management knowledge while optimizing the use of people, money, equipment and information. MEM is a strategically designed program that will provide graduates the opportunity to improve their management skills and their understanding of business practices which is very much necessary in today's highly competitive environment. Graduates of this program will become empowered to work in teams and understand managers from other disciplines including finance, human resources and marketing.

Course Requirements

Candidates are required to complete ten (10) subjects (60cps) according to the sequence of study listed below.

There are eight (8) compulsory subjects that are required to be completed along with two (2) elective subjects to be selected from the approved subjects provided each session.

Course Program

MEM Core subjects (8)

Code	Title	Credit points
ENGG 938	Engineering Economics	6 cp
ENGG 939	Engineering Logistics	6 cp
ENGG 951	Engineering Project Management	6 cp
ENGG 953	Modelling of Engineering Management Systems	6 cp
* ENGG 954 [capstone subject]	Strategic Management for Engineers and Technologists	6 cp
TBS 901	Accounting for Managers	6 cp
TBS 903	Managing People in Organizations	6 cp
TBS 905	Economic Analysis of Business	6 cp

Electives (2) – choose any 1 stream

Code	Title	Credit points
<i>Management Stream</i>		
MGMT 915	Management of Change	6 cp
MGMT 920	Organizational Analysis	6 cp
MGMT 978	Cross Cultural Management	6 cp
<i>Operations Stream</i>		
TBS 908	Supply Chain Management	6 cp
TBS 930	Operations Management	6 cp
<i>Total Quality Management</i>		
TBS 950	Quality in Management	6 cp
TBS 952#	Implementing Quality Systems	6 cp
TBS 953#	Management of Service Quality	6 cp

#TBS950 is a pre-requisite for these subjects

*Capstone: ENGG954 should be taken in the final semester.



IMPORTANT:

Please contact your Academic Advisor for the recommended subject sequencing for this degree

- Students are strongly encouraged to follow the subject sequence as discussed with your Academic Advisor to graduate in a timely manner.
- All subjects are not offered in all semesters and if the sequence is not followed, they run a risk of a delay in their graduation.
- If a student fails a subject, he/she needs to repeat the subject at the session it is scheduled for.
- The University has no obligation to offer a subject to meet the requirements of an individual student.

It is the responsibility of the students to check the subject offering in order to plan their degree.

4.9. Master of Information Technology Management

<i>Testamur Title of Degree:</i>	Master of Information Technology and Management
<i>Abbreviation:</i>	MITM
<i>Home Faculty:</i>	Faculty of Computer Science & Engineering
<i>Duration:</i>	2 years (5 sessions) full time or part time equivalent.
<i>Total Credit Points:</i>	60
<i>Starting Session(s):</i>	Intakes each session (Autumn, Spring, Summer).
<i>Delivery Mode:</i>	Face to Face
<i>Location:</i>	University of Wollongong in Dubai, Knowledge Village.
<i>Timing/Attendance:</i>	6:00pm – 9:00pm Saturday to Thursday.

Overview

The Master of Information Technology Management (MITM) degree program is designed to equip and prepare IT professionals working in various industries for the increasing complexities of the digital economy. Small business enterprises and large corporations are operating in a global and competitive environment, hence, the rising demand for IT experts who can automate organizational processes by utilizing the latest innovations in technology and business. Managing the growing pervasiveness of information and communication technologies in today's business has become a mandatory requirement for current technology professionals and IT managers.

Computer technologies, including hardware, software, networking, security, e-commerce and others are now integrated into the infrastructure of every organization. Competent IT managers are sought not only by companies engaged in the production or engineering of IT products but equally by existing and new service companies. The knowledge and skills necessary to anticipate, manage and implement business and technological advances that are critical to future business success are always highly in demand.

The Master of Information Technology Management will enable professionals to add value in the rapidly growing and dynamic IT industry of tomorrow. The program is intended to broaden the students' knowledge by providing them with a bridge connecting the academic environment and the outside world. MITM aims at making its graduates adept at coping up with the perpetually advancing industry of Information Technology and its application in business. Further, MITM allows students to make the appropriate business-technology decisions appropriate for today's changing business environment, and prepares them to become tomorrow's information leaders; thereby, enabling graduates to effectively plan and execute strategic information technology initiatives.

Course Requirements

Candidates are required to complete ten (10) subjects (60cps) according to the sequence of study listed below.

There are eight (8) compulsory subjects that are required to be completed along with two (2) elective subjects to be selected from the approved subjects provided each session by the College of Graduate Studies.

Course Program

MITM Core subjects (8)

Code	Title	Credit points
CSCI 925	Human Computer Interaction	6 cp
IACT 901	Information Technology Strategic Planning	6 cp
IACT 906	Business On-Line	6 cp
IACT 918	Corporate Network Management	6 cp
ITCS 937	Security, Risk Management and Control in Electronic Commerce	6 cp
TBS 903	Managing People in Organizations	6 cp
TBS 905	Economic Analysis of Business	6 cp
* IACT 999 [capstone subject]	Emerging Topics in Information Technology	6 cp

Electives (2) – choose any 1 stream

Code	Title	Credit points
<i>Management Stream</i>		
MARK 938	Managing Services & Relationship Marketing	6 cp
MGMT 915	Management of Change	6 cp
MGMT 978	Cross Cultural Management	6 cp
TBS 904	Marketing Management	6 cp
<i>Operations Stream</i>		
TBS 901	Accounting for Managers	6 cp
TBS 908	Supply Chain Management	6 cp
TBS 930	Operations Management	6 cp
TBS 950	Quality in Management	6 cp
<i>Finance Stream</i>		
FIN 928	Multinational Financial Management	6 cp
FIN 955	International Banking	6 cp
TBS 901	Accounting for Managers	6 cp
TBS 907#	Financial Strategy	6 cp
TBS 983	International Business Economic Environment	6 cp

#TBS901 is a pre-requisite for this subject

* Capstone: IACT999 should be taken in the final semester.



IMPORTANT:

Please contact your Academic Advisor for the recommended subject sequencing for this degree

- Students are strongly encouraged to follow the subject sequence as discussed with your Academic Advisor to graduate in a timely manner.
- All subjects are not offered in all semesters and if the sequence is not followed, they run a risk of a delay in their graduation.
- If a student fails a subject, he/she needs to repeat the subject at the session it is scheduled for.
- The University has no obligation to offer a subject to meet the requirements of an individual student.

It is the responsibility of the students to check the subject offering in order to plan their degree.

5.1 Master of International Studies

<i>Degree:</i>	Master of International Studies
<i>Abbreviation:</i>	MIST
<i>Faculty:</i>	Faculty of Arts and Humanities
<i>Duration:</i>	2 years – 5 semesters full time or part-time equivalent
<i>Total Credit Points:</i>	76
<i>Starting Session:</i>	Intakes every semester (Autumn, Spring, Summer)
<i>Delivery Mode:</i>	Face to Face
<i>Location:</i>	University of Wollongong in Dubai, Knowledge Village
<i>Timing:</i>	Sunday-Thursday, 6-9 pm

Overview

The Master of International Studies is a comprehensive program designed to provide background and theoretical approaches to understanding the relationships between nations and regions in areas such as globalization, diplomacy, economics, history, development, labour, culture, environment, and security.

Emphasis is placed on applying theories to practical problems in the greater Middle East and learning how to create policies that make sense in terms of local and regional historical and cultural background. Graduates of the program will be prepared to deal with problems relating to international issues that affect the UAE, the GCC, and the Middle East and South Asia region.

Course Requirements

Candidates are required to complete 9 subjects according to the sequence of study listed below. There are 6 compulsory subjects that are required to be completed along with 3 elective subjects to be selected from the approved subjects provided each session.

MIST Core Subjects: 6

Code	Title	Credit Pts
MIST902	Politics of International Relations and the Middle East	8
MIST906	Transforming MENA	8
MIST908	Globalization and Citizenship	8
MIST910	International Economic Relations	8
MIST926	Research Methods	8
MIST991	Thesis in International Studies	16 cp (taken over 2 semesters)

Electives: 3 with at least 20 cp

Code	Title	Credit Pts
MIST900	International Law and Diplomacy	8
MIST913	Labor and Migration	8
MIST920	Social Change and Development	8
MIST992	Internship in International Studies	8
MIST997	Advanced Topics in International Studies: Environment	8
MIST998	Advanced Topics in International Studies: Terrorism	8
MGMT978	Cross-Cultural Management	6
MMC925	International Journalism	6
TBS923	Current Issues in International Business	6

5.2 Master of Media and Communications

<i>Degree</i>	Master of Media and Communications
<i>Abbreviation</i>	MMC
<i>Faculty</i>	Faculty of Arts and Humanities
<i>Duration</i>	2 years (5 semesters) full time or part time equivalent
<i>Total credit points</i>	60
<i>Starting session</i>	Intakes in Autumn, Spring, Summer
<i>Delivery Mode</i>	Face to Face
<i>Location</i>	University of Wollongong in Dubai, KV
<i>Timing</i>	6-9 pm Sunday-Thursday

Overview

The Master of Media and Communications provides theoretical background and advanced skills in media studies and public relations. The program is intended to prepare professionals for work in a new field or to support and polish the skills of those already working in an area of media and communications. While emphasis is placed on conditions of work in the UAE and the greater Middle East region, the theories and skills are applicable around the world in developed as well as emerging markets.

The Master of Media and Communications has two specializations: Media Studies and Public Relations. The direction in media and communications in the 21st century has been toward working alone as well as in teams on projects of all sizes. Today's journalist or PR specialist often functions as a one-person operation responsible for writing, recording audio and video, editing, and producing material for various platforms. Higher level versions of these skills figure in feature films and documentaries.

Program Requirements

Candidates are required to complete 9 subjects (60 cp) according to the sequence of study listed below. There are 6 compulsory subjects that are required to be completed along with 3 elective subjects to be selected from the appropriate major.

Six (6) Core Subjects: (42 credit points)

Code	Title	Credit Pts
MMC910	Journalism and Society	6
MMC911	Introduction to News Writing	6
MMC912	Legal and Ethical Issues	6
MMC915	Design and Desktop Publishing	6
MMC913	Introduction to Convergence Journalism (for Journalism and Media Studies) OR	6
MMC929	Public Relations Research (for Public Relations and Professional Writing)	6
MMC935	Internship, Practicum, Thesis, Major Project, or Professional Portfolio	12cp (taken over 2 semesters)

Electives: Select 3 subjects from a specialization (18 credit points)

Specialization in Media Studies

Code	Title	Credit Pts
MMC923	TV Journalism	6
MMC926	Film and Cinema Studies	6
MMC927	Media Management	6
MMC928	Marketing Media	6

Specialization in Public Relations

Code	Title	Credit Pts
MMC930	Public Relations Publics	6
MMC931	Public Relations Processes	6
MMC932	Public Relations Programming and Production	6
MMC933	Case Studies in International Public Relations	6

Subject Descriptions

CSCI925 Human Computer Interaction

Description: This subject is designed to help managers of information technology projects understand and appreciate issues that affect the usability and utility of software, from a user point of view, and how to ensure that introducing new software to the organization will improve work processes and increase productivity. The subject examines the design, evaluation and implementation of interactive computing systems for human use and the major phenomena surrounding them. Students will be introduced to methods and techniques used in evaluating user needs and the usability of the interactive system. They will be given the essential theoretical background to HCI approaches, methods and techniques followed by practical experience in conducting deferent types of usability evaluations.

ECON939 Quantitative Economic Analysis

Description: This subject develops the fundamental concepts of econometrics used in applied economic work in the academic, business and government sectors. The subject covers the standard and non-standard econometric models based on time series, cross-section and qualitative data. Emphasis will be on applications of the econometric methodologies to empirical research.

ENGG938 Engineering Economics

Description: Engineers today are not limited to the core of their activities being in the technical area but also the strategic and operational decision making processes. The aim of this course is to familiarise engineering students to the field of economics and its relevance and importance to the field of engineering. Initially, the course looks at a broad definition of economics and the basic elements of microeconomics such as concepts of supply and demand, market equilibrium and price elasticity. Macroeconomic issues are covered next with focus on GDP, inflation, unemployment, phenomenon of business cycles, and the financial markets. The core of the course examines the time value of money and how engineers use this concept for making crucial economic decisions. Future values of capital investments and their links to interest rates and compounding periods is investigated. Future values and present value of annuities, bond and mortgages are also explored. Using the tools developed, the course then applies them in the determination of net present values, internal rates of return and payback periods of diverse investment opportunities. Replacement analysis of capital equipment is examined as well. The implications of taxes, inflation and depreciation for capital budgeting are explored.

ENGG939 Engineering Logistics

Description: Logistics in this course focuses on the design, development, production, distribution, and sustaining support of "systems" throughout their planned life-cycle(s). This course will concentrate on logistics from a systems engineering perspective; i.e., the design of systems for supportability and serviceability, the production

and effective distribution of systems for customer use, and the sustaining maintenance and support of systems throughout their period of utilization. Logistics is one of the key elements in sustaining a system and it is important that to successfully accomplish its mission logistics design must be tailored on a total life cycle basis.

ENGG951 Engineering Project Management

Description: Topics will cover: Scope Management, Time Management, Human Resource Management, Risk Management, Financial Management, Project Plans, Project Quality Management and Procurement & Contract Management.

ENGG953 Modelling of Engineering Management Systems

Description: Concentrating on the search of appropriate operations research techniques to assist in the solution of engineering management problems and basic experimental design. Topics include:- the basic principles of modelling, decision support models, modelling failure processes, search methods, scheduling models, queuing theory and its application, data collection and design, introduction to experimental design, principles of design, importance of randomisation, simple comparative experiments, experiments with a single factor, randomized blocks and related designs, introduction to factorial designs, Taguchi's philosophy of design.

ENGG954 Strategic Management for Engineers and Technologists

Pre-requisite: Capstone Subject. This subject should be taken in the final semester of MEM degree program

Exclusion: TBS921, MGMT910

Description: The subject introduces engineers and technologists to strategic management. This includes basic principles of analysis, decision-making and implementation. The aim is to create awareness of strategic issues in engineering and technology based organisations. This includes an appreciation of competitive leverage from technology decisions. A need for consciousness of these issues amongst engineers is crucial to their function in both profit and not for profit organisations.

FIN922 Investment Management

Description: This subject is about the tools and logical frameworks with which decision makers choose their investments in a world characterised by uncertainty (risk). Emphasis is on investment in financial assets such as shares, bonds and futures rather than on real assets. Particular subjects covered include portfolio choice, allocations of investments between risky and riskless assets, the term structure of interest rates, asset pricing models, options pricing and hedging with derivatives.

FIN923 Portfolio Management

Pre-requisite: Capstone subject. This subject should be taken in the final semester of MAFB degree

Description: This subject examines advanced topics in the modern theory of optimal investment decision-making, portfolio theory, capital and derivative markets. The subject explores several major areas of interest including market efficiency models in valuing portfolios and securities, bond analysis, portfolio management and

performance evaluation. The subject provides a theoretical framework within which all derivative securities can be valued and hedged and also examines the way in which they are traded.

FIN924 Financial Statement Analysis for Business

Description: This subject examines the framework for financial statement analysis with discussion of the role of accounting information and intermediaries. Emphasis is on the appraisal and prediction of corporate financial performance from publicly available information such as accounting numbers, industry and economic statistics as well as other stock market data. Cases and problems are gradually introduced, provoking an analytical and creative thinking process ending with the evaluation and preparation of appropriate business strategies.

FIN925 Banking Theory and Practice

Description: This subject examines bank management theory as applied to the practice of bank operations within the banking sector. It entails comprehensive discussion on issues that are commonly involved within the banking environment such as the regulatory structure, risk management, commercial and consumer lending, capital adequacy analysis, banking financial futures and forwards, the cheque clearing system and the latest information technology within the banking world.

FIN926 Advanced Managerial Finance

Description: This subject examines advanced aspects of financial controllership and corporate finance within the contemporary business environment. The subject first analyses the impact of less-than-ideal capital markets, information asymmetries and principal-agent conflicts on practical decision-making in the firm. It then investigates several specialised areas receiving increased scrutiny from corporate stakeholders including financial distress and restructuring, corporate governance, organisational architecture and risk management, debt and equity strategies, and mergers and acquisitions.

FIN928 Multinational Financial Management

Description: This subject examines international finance and investment from the perspective of the multinational corporation. Topics studied include various aspects of the international monetary system, the Euromarkets, foreign exchange markets, internal and external exposure management techniques, currency futures and options, swaps, financing multinational corporation investment, multinational corporation investment decision making, political risk analysis and international taxation.

FIN955 International Banking

Description: The global impact of banking is the focus of this subject. The subject incorporates comprehensive discussion of issues that commonly arise in the international banking environment. These include the development of the international monetary system, the deregulation of banking, methods of payment in international trade, foreign exchange markets, international lending and developments of new technology.

FIN956 Bank Lending and Securities

Description: This subject examines the bank's lending process and the securities associated with it. The subject includes comprehensive discussion on issues concerning lending within the banking environment, including regulation of security offerings, principles of good lending, documents involved in lending, lending and the consumer credit code, new developments in lending and securities and their impact on the banking sector.

IACT901 Information Technology Strategic Planning

Description: The subject is essentially about the application of technology for competitive advantage. Throughout the subject, the emphasis will be based on techniques and frameworks for "thinking strategically about a company's technological orientation". A wide spectrum of business and technology issues will be covered that address the problems and issues surrounding the analysis and development of an IT strategic plan. Also, students are expected to research the current magazines, journals and electronic media for latest findings and examples on the appropriate strategies used to manage technology and innovation.

IACT906 Business On-Line

Description: This subject aims to provide students with an understanding of e-business in the context of today's global business environment. Today most businesses compete in a global environment; a sound business strategy for on-line business is essential to facilitate this. This subject covers key areas of e-business, including: Strategy formulation and implementation; e-branding; service leadership; economics and industry impacts of e-business and Internet effectiveness.

IACT918 Corporate Network Planning

Description: The subject investigates the documentation and management of telecommunications networks. Topics to be covered include, but are not limited to:

- Documenting the network: requirements capture and specification, functional specification, design specification, documenting the network configuration.
 - Managing the network: influences on the network, management architectures and standards, performance management, fault management, disaster management, managing changes in a network, cost management.
 - Corporate and regulatory requirements: management teams, operations and support, standards and protocols.
-

IACT999 Emerging Topics in Information Technology

Pre-requisite: Capstone. This subject should be taken in the final semester of the MITM degree

Description: This subject is concerned with the emerging issues involved in the analysis, design, development and implementation of a corporate-wide information system. Students will complete an individual project/business case related to the strategic use of IT in an organization. Students are required to apply their experience and knowledge from previous subjects, as well as a set of research methods to prepare a report and presentation.



Projects will be undertaken individually and specific topics will be selected based on the student's chosen elective stream and interests. The subject also provides students with enhanced communication and project management skills.

ITCS937 Security, Risk Management and Control in Electronic Commerce

Pre-requisite: IACT918

Description: This subject aims to provide students with a deep understanding of the security, risk management and regulatory aspects of e-commerce facing businesses in the on-line business environment. Today most businesses compete in a global business environment; a sound business strategy that addresses these issues is essential. This subject covers key issues in e-commerce, including: security options, trusted authorities, secure payment systems for the Internet, the regulatory environment and government policy; risk management and control.

MARK917 Business to Business Marketing

Description: This subject will give students an appreciation of the differences between organisational and consumer customers. Organisation buying practices are different from the processes of consumers and as a result marketing strategy and operations have distinctly different imperatives. With a much higher level of rationality in decision making, there is a far greater focus on product management and innovation as a source of competitive advantage. There is also a far greater focus on logistics and distribution functions as reliability of supply is a key need of customers, particularly when product delivery has to interface directly with customer operations. The central role of personal selling in the promotional mix is also dealt with in depth as it is critically important in generating sales and maintaining relationships with customers.

MARK922 Marketing Management

Exclusion: TBS904

Description: This is the introductory postgraduate Marketing subject. It examines the contemporary view of marketing and focuses on the following areas: identification of market opportunities, segmentation and target marketing, marketing mix decisions, service marketing and international marketing.

MARK935 Marketing Strategy

Pre-requisite: Capstone Subject. This subject should be taken in the final semester of the MSM degree program

Description: With the use of case studies, this subject will examine the development and implementation of marketing plans and strategies at the organisational level. Key issues may include: marketing's strategic role in the organisation, marketing strategy and competitive advantage, including marketing mix strategies, marketing strategy formulation, implementation and control.



MARK936 Consumer Behaviour

Description: The subject will explore the motives of consumers during the purchase of products and services. It will investigate sociological and psychological concepts as they specifically apply to the behaviour of consumers in order to learn how to make more effective marketing decisions. In addition to a required text that will be used to understand the theory, readings and case studies will be assigned for practical application of the concepts.

MARK938 Managing Services and Relationship Marketing

Description: The aim of the subject is to introduce the graduate student to a theoretical and practical perspective of the service industry, its marketing implications, and managing buyer-seller relationships. The subject is intended for students who are interested in how to cope with service competition in a customer-oriented manner. The subject will not only deal with issues relating to managing customers in service firms, but is equally intended for manufacturers of physical goods operating in business-to-business or consumer markets because the importance of service to success is constantly growing for such firms. Because services and relationships are interrelated, the subject will deal with customer relationship management and relationship marketing as well as services management.

MARK940 Marketing Communications

Pre-requisite: MARK936

Description: This subject will provide both a theoretical and a practical perspective on Marketing Communications and Promotion Strategy. Students will learn to use communication tools such as advertising, sales promotion, point-of-purchase materials, sponsorship programs and publicity, to optimise intervention on organisational issues.

MARK959 Sales Management

Description: This course involves organising and planning the company's overall personal selling efforts and integrating these efforts with the other elements of the firm's marketing strategy. It also includes the selecting of appropriate sales personnel and designing and implementing policies and procedures that will direct their efforts towards the firm's desired objectives. The final part of the course involves developing procedures for monitoring and evaluating sales force performance so that adjustments can be made to either the sales program or its implementation when performance is unsatisfactory.

MARK977 Research for Marketing Decisions

Description: This subject focuses on the role & practice of marketing research in marketing. Marketing research can be defined as the systematic collection, analysis and interpretation of data about market-related and other consumer behaviour, using research methods derived from the behavioural & social sciences. Marketing research is an important means through which all types of organisations can obtain reliable and valid information about their markets, customers or clients in order to inform their marketing-related decisions. This subject will provide an overview of marketing research as an applied practice and will emphasize the practical aspects of doing research

to meet client needs. It will cover the marketing research process beginning with client consultation and research design, as well as data collection, data analysis and report preparation.

MARK997 Retail Marketing Management

Description: This subject will include a background to retailing, the scope of retailing, retailing strategies, merchandise and store management. Particular emphasis will be placed on case analysis in order to bring as much of the real world as possible into the classroom.

MGMT908 Human Resource Development

Description: This subject provides an advanced perspective on the use of Human Resource Development (HRD) in enhancing the competitive advantage of organisations, by building up the intellectual and learning system capacities of the organisation to cope with a rapid change, customer focused environment. The concept of the Learning Organisation will be developed through the perspective of the HRD policies and actions required to develop and change organisations through their human capital and capabilities.

MGMT910 Strategic Management

Exclusion: TBS921, ENGG954

Description: This subject introduces students to theories, concepts and practical issues associated with the strategic management. Topics examined include strategy formulation, choice and implementation; strategy and structure and the organisational context; industry analysis; strategy and competitive advantage.

MGMT915 Management of Change

Description: This subject analyses how managers can conceptualise and lead the process of organisational change. Issues under discussion will be: organisational change theories and models; forces for change; resistance to change; coping with change; recognising, diagnosing, planning and implementing change; organisational development; contingency approaches to change; and aspects of cultural change management.

MGMT920 Organisational analysis

Description: This subject provides students with an understanding of the main theoretical frameworks and conceptual tools used to analyse organisations. The subject approaches organisational analysis using four perspectives: bureaucratic, contingency, political, and cultural. Emphasis is placed on understanding the basis in theory and metaphorical roots of each perspective, as the foundation for using a multiple perspectives approach to identify the key dynamics of organisations.

MGMT930 Strategic Human Resource Management

Pre-requisite: Capstone Subject. This subject should be taken in the final semester of MSHRM degree program



Description: This subject examines strategic management concepts and frameworks, and explores the links between strategic management and human resource management. A number of models of strategic HRM are considered, in terms of their theoretical foundations and practical utility. The overall focus is on using the conceptual and analytical frameworks of strategic HRM to develop and implement effective human resource strategies.

MGMT949 Performance Management

Description: This subject examines the area of performance management, which is defined as an ongoing communication process that involves both the performance manager and employee. Key aspects of this process are examined. Topics include: identifying and describing essential job functions and relating them to the mission and goals of the organisation; developing performance standards; giving and receiving feedback about performance; writing and communicating constructive performance evaluations, and planning education and development activities to maintain and improve or build on employee work performance.

MGMT953 Human Resource Management

Description: This subject addresses key areas associated with the functional specialisation of human resource management, and expects these to broaden the organisational context. It focuses on major functional policies and programs such as human resource planning, strategic HRM, job analysis, employment law, recruitment and selection, performance management, compensation, human resource development, occupational health and safety and international HRM. Students are encouraged to draw upon their work experiences in classes and assignments to enhance learning.

MGMT969 Job Analysis, Recruitment and Selection

Description: This subject examines contemporary issues and theory related to the environment and processes of organisational entry, involving the key phases of job analysis, recruitment, selection and socialisation. Traditional recruitment strategies are assessed from the perspective of the organisation and the individual in light of contemporary theoretical developments. A range of personnel selection techniques is examined in relation to issues of reliability, validity, fairness and applicability. In addition, there will be a focus on major challenges faced in these processes in the light of rapidly changing technologies and globalisation. Organisational entry processes will be critically evaluated in the context of differing cultural expectations and practices. A range of practical skills in recruitment and selection processes will also be developed.

MGMT978 Cross Cultural Management

Description: The subject addresses key issues and problems associated with managing across cultural boundaries in a context of increasing global contact. Topics include: cross cultural communication, technology, comparative management practices, managing with multicultural policies, and the challenges cultural differences posed for international/global managers.

MIST902 Politics of International Relations

This subject is an introduction to international politics. It surveys the major theories of international relations and some of the newer approaches before examining contemporary relations between states, peoples, and non-state actors. Realism, liberalism, Marxism, and social constructivism are viewed in terms of contemporary global politics. Major trends after the end of the Cold War are considered and the emergence of the US-led global order and the challenges to it. The workings of the United Nations, the global financial crisis, peacekeeping, human rights, sovereignty, and security as well as so-called failed states are assessed. This course also seeks to apply the broader debates and discussions within International Relations to the Middle East.

MIST906 Transforming MENA

This subject is an introduction to international politics. It surveys the major theories of international relations and some of the newer approaches before examining contemporary relations between states, peoples, and non-state actors. Realism, liberalism, Marxism, and social constructivism are viewed in terms of contemporary global politics. Major trends after the end of the Cold War are considered and the emergence of the US-led global order and the challenges to it. The workings of the United Nations, the global financial crisis, peacekeeping, human rights, sovereignty, and security as well as so-called failed states are assessed. This course also seeks to apply the broader debates and discussions within International Relations to the Middle East.

MIST908 Globalization and Citizenship

This subject examines the effects of globalization on representations of identity and citizenship in the Middle East and South Asia. Contemporary challenges to state authority coming from grassroots movements for democracy and universal human rights; women's groups; ethnic minorities and indigenous peoples seeking self-determination; and the mass migration of workers and refugees are discussed.

MIST910 International Economic Relations

This subject explores issues and theories central to modern international political economy. It begins with an exploration of the historical and theoretical debates about political economy from mercantilism to liberalism, protectionism, Keynesianism, and neoliberal globalization. It then focuses on current debates over the role of states and international economic regimes in development. The World Bank, the International Monetary Fund (IMF), and the World Trade Organization (WTO) are examined, along with the effects of the 2007 global financial crisis.

MIST926 Research Methods

This course will cover research methods and research design in the social sciences. It is divided into four parts: (1) the goals of social science and elements of research design; (2) selection and application of different



methodologies for conducting research; (3) collection of primary and secondary data; and (4) analysis and synthesis of qualitative data in the research writing process. The ethical implications of social research will be considered throughout. Social research is a craft, and like any other craft, it requires practice. Therefore, the approach will be hands-on from the start. Students will learn by doing in all aspects of the course—in class meetings, the computer lab, and out-of-class assignments.

MIST900 International Law and Diplomacy

This subject examines the foundations of international law, how it operates, and how representatives of states and international organizations work. It explores what diplomats do and the limits of diplomatic action. The initial lectures provide students with the theoretical tools to understand how the system of international law has evolved and how international instruments are constructed and ratified. Specific topics that may be addressed in terms of their effect on diplomacy include: the sources of international law; the structure of the international legal system; the relationship between domestic law and international law; the law of treaties; statehood, state jurisdiction and state responsibility; personality, statehood and recognition; human rights; and refugee laws.

MIST913 Labor and Migration

This subject is concerned with the ways in which migration and labor mobility have influenced social transformation in the Middle East, North Africa, and South Asia region (MENASA). These issues are examined at the conceptual level and through case studies in specific countries. Special attention will be given to migration to and within the Gulf states. Labor migration is analyzed both in terms of individual migration experiences and in relation to the broader social, political, and economic effects on sending and receiving countries. Themes include the formation of multi-ethnic societies, development of labor movements, citizenship rights for workers, discrimination and marginalization of labor communities, and increased migration of women. Cross-disciplinary approaches will be introduced to offer a range of theoretical approaches to these issues, and state policies regarding the implementation of immigration policies will be studied.

MIST920 Social Change and Development -

This subject introduces students to problems of inequality in wealth and welfare from a global, comparative, and historical perspective. The causes and consequences of inequalities among countries, as well as gender, class, ethnic and regional stratification, are examined. Major theoretical perspectives on international development and global social change are studied and applied to an analysis of contemporary social issues. Taking an interdisciplinary approach, this subject examines development as a concept, paradigm, experience, and practice. Following an examination of the main issues and theoretical approaches (modernization, dependency and World System) that have informed the study of development, these approaches are applied to recent development strategies pursued in the MENASA region. Comparative analysis will emphasize the interplay between domestic and international factors in shaping the paths to socio-economic transformation in these countries and evaluate

current thinking about how to attack the challenges posed by domestic corruption and continuing poverty. Case studies will explore local understanding of what constitutes development.

MIST997 Advanced Topics in International Studies: Global Environmental Politics

This subject examines contemporary international environmental problems from theoretical and policy perspectives: how environmental problems are defined and identified by scientists and activists and the various political solutions proposed? What are the causes of environmental problems? What strategies do international actors use to address these problems, and which are most successful? What are the most pressing problems facing policymakers today? How do environmental issues lead to problems in areas such as security and economics? To shed light on these questions, this subject first analyzes structures, agents, and processes affecting international environmental politics. Then the subject focuses on contemporary issue areas including the use of natural resources, overpopulation, pollution, energy use, global climate change, environmental security, and potential future problems.

MIST998 Advanced Topics in International Studies: Terrorism and Security

Given the controversial nature of the subject and the events of September 11, 2001, public discourse is often emotionally charged and lacking factual grounding and objective analysis. This subject will attempt to get at the roots of terrorism and analyze the various facets associated with this phenomenon: Why does terrorism occur? What are its international and domestic sources? How do scholars in the field of terrorism research explain it? Students will be introduced to examples of contemporary terrorism, with a particular focus on the Middle East and the post 9/11 security environment. After an initial focus on conceptual issues, the class will explore case studies such as Al-Qaeda and Bin Laden as the prototype of a contemporary terrorist group, the Lebanese Shia group Hezbollah, Hamas in Palestine which some do not consider terrorist, and others.

MIST992 Internship or Practicum

Students who are working full time may prefer a practicum that involves producing a special report or undertaking a job function that is not part of normal duties at the organization where they work. The arrangement should be proposed and negotiated by the student with the approval of a key supervisor on the job and the student's advisor and the program director at UOWD. If a new job function is selected, the student will produce an extensive report on that.

Students who are studying full time may prefer an internship, defined as 10 weeks of full time work at a company or organization performing duties that reflect learning and practice during the Master's program. The student will be required to maintain a daily written record of work activities and reflect on them, the job, and the organization. To receive full credit, the student will submit this document at the end of the internship; the supervisor(s) at the organization will be asked to submit a letter evaluating the student's performance on the job. An unsatisfactory evaluation by the supervisor(s) means the student cannot earn credit for the internship.



MIST991 Thesis

Writing a thesis is the most traditional way of demonstrating intellectual depth and professional competence at the end of a master's degree program. The approach may be qualitative, quantitative, or mixed; topic and scope must be agreed with the student's advisor and the program director before the student embarks on the thesis. A thesis in International Studies is a synthesis of existing literature, original research, analysis, and exposition at a professional level. It is at least 15,000 words and may reach as many as 25,000.

MMC910 Journalism and Society

The purpose of this subject is to explain the relationship between theory and practice. While some critics may question whether a theory of journalism exists, or is even necessary, many academics will argue that the practice of journalism is underpinned by a strong theoretical tradition that draws from a range of other disciplines. The subject begins by posing a number of questions: What is journalism? What is it that journalists actually do? It then moves on to discuss questions about news practices and techniques. Topics include gate keeping, agenda setting, framing the news, spiral of silence, uses and gratifications, cultivation effects, and structural functionalism in old and new media.

MMC911 Introduction to News Writing

This subject develops skills in straight news reporting for print and online news. Attention will be given to objective and subjective aspects of news interviewing, structuring, and writing. News story areas covered will include writing hard news, as well as color stories, profiles, and human interest stories. Students will apply news writing techniques to tackle different beats and explore some of the issues and stylistic devices that inform longer news related features and news packages. Attention will be paid to interviewing and information gathering techniques and the application of conventional news values to reporting.

MMC912 Legal and Ethical Issues

This subject examines the legal and ethical framework, which governs the work of journalists. It considers the nature, efficacy, and administration of ethical codes relevant to journalism, particularly the Australian Press Council's Statement of Principles. The UAE Journalists' Association's Code is also considered as are the U.S. First Amendment, the UN Declaration on Human Rights, and other texts. Other aspects of professional conduct and professional standards considered include defamation actions, libel laws, breach of privacy, confidentiality, protection of sources, standards of accuracy, fairness, and subjectivity in journalism.

MMC915 Design and Desktop Publishing

This course gives graduate-level introduction to digital media tools necessary in professional media production, communication and design. The course will cover file creation and editing, compression, and content transmission. Over the semester, students will explore professional tools as well as the production possibilities with consumer applications and freeware.

MMC913 Introduction to Convergence Journalism

Convergent journalism makes use of changes in journalism inspired by the development of the internet and other technologies. In this subject, theories and practices of digital media are introduced including photojournalism and simple audio techniques suitable for production of online audio visual packages. A range of topics including building a blog and podcasting lead to students developing and maintaining a blog, learning to podcast, and using a combination of text and images to develop their own web-based publication.

MMC914 Advanced Reporting

This subject assumes the student has reportorial skills in traditional and online journalism and wants to develop them in the direction of in depth reporting about social, environmental, or business issues. In finding and developing areas of interest, the student will create professional level work in print and digital media.

MMC916 Information Gathering

Finding factual proof or backing to substantiate a claim or theory explains the importance of information gathering for journalists. They need to be familiar with statistical databases and their uses. This subject engages the student in hunting for credible and relevant sources online and elsewhere to contribute to, expand, or question the story he/she is pursuing.

MMC917 Feature Writing

Extending news stories into feature writing, taking into account ethical and legal restraints, is an essential technique for journalists. Topics covered include feature story introductions; feature story structures; dialogue and characterization; scene descriptions; feature length interviews; online and conventional research; and developing concepts. Formats for features such as profiles, news features, historical features, reviews, and opinion essays are covered.

MMC925 International Journalism

This subject explores international news flow in the context of the New World Information Order debates in the early 1970s and Internet communication; culture, values, and ideology in international news production (discussions of internal and external reporting of the Middle East and the UAE); media systems in US, UK, South Asia, and the rest of the world; and renewed interest in community development oriented journalism. International journalism provides historical, cultural, and social background for students wanting to work in the global multicultural media or any area where such knowledge is useful.

MMC923 Television Journalism

In this subject advanced skills in script writing, editing, producing, and presenting television news or current affairs programs are developed. A primary emphasis is placed on techniques for gathering television news materials in the field.

MMC926 Film and Cinema Studies

An in depth introduction to narrative film that covers historical milestones, major genres, and concludes with an examination of film in the UAE and the Middle East and the developing film industry in the region. Students follow and working with the international film festivals in Abu Dhabi, Dubai (2), and Doha, Qatar during the fall semester and analyze the winning films from those festivals in the spring and summer semesters.

MMC927 Media Management

Media is a word that encompasses some of the most interesting companies in the world that affect the lives of more and more of the world's citizens. How these companies survive in the global marketplace and how they thrive or endure in their local markets is a function of how they are managed. This subject covers economic issues, corporate leadership, narrow or wide focus activities, and future trends in technology that affect media management today and in the future.

MMC928 Marketing Media

This subject covers integrated marketing of media organizations and how media itself acts as a marketing channel. The dual focus provides an introduction to marketing basics and addresses the role of the media in distributing information for itself and on behalf of others. Students identify goals of marketing, define research to provide preliminary information, target their market segments, create marketing campaigns including advertising and public relations, work on pricing and distribution strategies, and observe the organization's business objectives.

MMC920 Introduction to Professional Writing

An introduction to the various forms of professional writing with emphasis on purpose, structure and limitations including television, radio, and new media as well as writing for organizations. Students will create a portfolio of work as a component of the class. The course refines students' research and writing skills to help them advance scholarly or professional aspirations.

MMC921 Writing Major Reports

Writing in an organizational context is important in business, academe, and the nonprofit world. Informational writing in long form incorporates research – both created specifically for the writing or compiled from existing material - and includes annual reports; HR manuals; case studies; analyses of industry problems; SWOT reports or environmental surveys; how to guides; and many categories.

MMC922 Grant Writing

Grants are increasingly important in the government, nonprofit, and academic sectors, but writing a successful grant proposal requires understanding of how the process works. This subject covers how to find opportunities for grants, write a preliminary proposal, attract a request for proposal, produce the grant proposal, provide supplementary materials, and maintain contact with grant givers.

MMC934 Editing Professional Writing

Students learn principles of copy editing with focus on longer formats and technical pieces. Copy editing exercises will be combined with editing submissions to academic journals and chapters in books published by the University of Wollongong in Dubai.

MMC929 Public Relations Research

This course includes the application of social science research to the planning, implementation and evaluation of strategic public relations practices. Students should gain familiarity with quantitative and qualitative research methods, experimental design, sampling, data analysis, report writing, research ethics and challenges of researching minority groups.

MMC930 Public Relations Publics

This subject includes studies of publics and their relational interests in and consequences on organizations. Students learn the situational theory of publics; activism theory; and theories of power, risk communication, crisis



communication, relationship and relationship management, identity, gender, culture and other dimensions of diversity.

MMC931 Communication Processes

In this subject, students learn theories and practices of communication including organizational, interpersonal, intercultural, small group, persuasion, rhetorical, and conflict resolution. Current PR practice in the Middle East and internationally is examined in the light of theories.

MMC932 Public Relations Programming

This course covers advanced principles and practice techniques, particularly those related to the use of new technology, the Internet and telecommunication. Students should become proficient in research- based strategic planning, audience analysis, message development and design and distribution channels.

MMC933 Case Studies in International Public Relation

International public relations calls for using the best tools of public relations plus awareness that what seems natural or obvious in some markets may be understood negatively in others. By analyzing examples of best public relations practices in a number of countries, students will acquire a framework for their work in the Middle East and the GCC.

MMC935 Internship, Practicum, Thesis, Major Project, or Professional Portfolio

This subject provides five ways for students to demonstrate the depth of their understanding of an area of knowledge, their skills, and their professionalism. Which one they select depends on work situation, concentration, and prior work in the core and elective subjects. Students will make a choice in consultation with their advisor and the program director.

Students who are not working may prefer an internship, defined as three months of full time work at a company or organization performing duties that reflect learning and practice during the Master's program. The student will be required to maintain a daily written record of work activities and reflect on them, the job, and the organization. To receive full credit, the student will submit this document at the end of the internship; the supervisor(s) at the organization will be asked to submit a letter evaluating the student's performance on the job.

Students who are working full time may prefer a practicum that involves producing a special report or undertaking a job function that is not part of normal duties at the organization where they work. The arrangement should be proposed and negotiated by the student with the approval of a key supervisor on the job and the student's advisor and the program director at UOWD.

Producing a thesis is the most traditional way of demonstrating intellectual depth and professional competence at the end of a master's degree program. The approach may be qualitative, quantitative, or mixed; topic and scope must be agreed with the student's advisor and the program director before the student embarks on the thesis.

Students in some concentrations may prefer to demonstrate their analytic and production skills by creating a major project, for example, a documentary, a narrative film, or an investigative report. Topic, approach, and scope must be agreed first with the student's advisor and the program director.

For some students a professional portfolio may be the best way to fulfill the subject requirement. The body of written, digital, or media work of professional standard they produce will be evaluated by their advisor, the program director, and an outside expert in a related field.

TBS901 Accounting for Managers

Exclusion: TBS980

Description: This subject is intended for those who need to obtain a better understanding of the principles of accounting and financial management. No previous knowledge or experience is assumed. The subject will introduce you to the role that effective financial management makes within an organisation. The aim is to make you proficient in the use of the accounting data that you receive in your work environment, as well as making you aware of the basis on which key financial decisions are made. You will be introduced to the basic concepts of financial decision-making and the role of financial management in both private and public sector organisations. The concepts and techniques will assist you in the use and interpretation of accounting data and you will become better acquainted with the planning and controlling of resources you have at your disposal.

TBS902 Statistics for Decision Making

Description: This unit will provide an in-depth introduction to probability, decision theory, and statistical inference with emphasis on solutions to actual business problems. After developing a foundation in probability theory, the subject will extend this foundation to a set of methodologies for the analysis of decision problems. The unit examines structures for managerial decision making under conditions of partial information and uncertainty. The examination of the use of statistical techniques in managerial decision making processes, including, confidence intervals, hypothesis testing, quality control, linear and multiple regressions should be applied in realistic case situation.

TBS903 Managing People in Organisations

Exclusion: TBS981 (Managing in Multi-National companies)

Description: This subject introduces students to ideas about managing people in organisations which thematically combine theories and research in organisational behaviour and human resource management. The subject encourages students to think about management and organisations in ways which are multi-disciplinary, problem

solving and critical. It encourages intellectual inquiry and debate using a range of sources: theoretical, journalistic, historical, comparative and quantitative. The subject encourages students to evaluate popular management fads in the light of more rigorous theorising and research. It aims to improve the research, critical thinking, writing and speaking skills of students

TBS904 Marketing Management

Exclusion: MARK922

Description: This subject examines the contemporary view of marketing and focuses on the following areas: identification of marketing opportunities; market segmentation; targeting and positioning; product life cycle; new product development; services marketing and marketing mix decisions.

TBS905 Economic Analysis of Business

Description: This subject aims to introduce students, and develop their understanding of, core economic concepts relevant to business and managerial decision-making, in order that they may identify and interpret those economic events and circumstances which influence the operations of business. Commencing with the (microeconomic) examination of the behaviour of individual economic units, the subject develops to provide a view of macroeconomics and its application to the functioning of the economy overall. National accounts systems are introduced, and the macroeconomic approach that is relevant to an open economy of the type in which real businesses operate. It is a course objective to equip students to be able to read and understand published articles on business and the broader economy, and interpret these as to their impact on business and government organisations, and such material will be used in class.

TBS906 Information Systems for Managers

Description: This subject provides an understanding of the management of information systems in organisations, in particular, it provides an analysis of the approaches to managing information and knowledge as well as the techniques for ensuring information quality. Other issues considered are the creation of strategies to resource and control information flows and usage within an organisation; the management of information system projects and the impact of change their implementation has on staff; the use of technology and people to improve the quality information services.

TBS907 Financial Strategy

Pre-requisite: TBS901 or TBS980

Exclusion: FIN921

Description: This subject provides an introduction to the theory and practice of financial management. The financial manager plays a key role in the development of a company's strategic plan. In particular s/he is concerned with providing advice on which investment opportunities should be undertaken and how they should be financed. Both of these decisions should be taken in the context of maximising the value of the investment made in the company by its shareholders. Investment of funds in assets determines the size of the company, its profits from operations, its business risk and its liquidity. Obtaining the best mix of financing and dividends determines

the company's financial charges and its financial risk; which in turn impacts on its valuation. It is the aim of this course to examine many of these issues.

TBS908 Supply Chain Management

Description: Supply Chain Management extends the study of logistics beyond the boundaries of a single organisation, and places particular emphasis on the interfaces between the 'chain' or 'network' of enterprises engaged in moving products, services, and information, from suppliers through intermediaries to end users/consumers. The early part of the subject focuses on understanding the concepts and principles of supply chain management. Supply chain infrastructure and operations topics are reviewed giving emphasis on topics such as JIT, lean, and agile supply chain. Channel relationships between suppliers, manufacturers, and distributors is also reviewed, particularly as leading organisations are now openly embracing more collaborative behaviour for mutual benefit. Transformational change in supply chains is studied from two perspectives, i.e., re-alignment inside the supply chain itself, and new advanced forms of 'outsourcing'. Finally, we live in Asia Pacific, so it is important to understand the regionalisation of supply chains which is well underway, and in some cases, globalisation.

TBS909 Corporate Governance

Description: The broad aim of this subject is to identify, explain and evaluate the sometimes competing approaches to corporate governance that have defined the terms of the governance debate, to assess the role of public policy in designing and overseeing effective systems of corporate governance and to examine the relationship between governance issues and business. This will provide students with a sound understanding of the complex issues that have to be faced by industry and government in developing effective corporate governance systems.

TBS912 Quantitative Methods for Decision Making

Description: This subject focuses on the quantitative techniques available to managers in problem solving and decision making in businesses. The subject aims to develop in students the skills necessary for data analysis, model building and analysis for business decision-making. To this end the subject covers areas such as decision making under certainty and uncertainty, linear programming, transportation and transshipment techniques, project scheduling with certainty and uncertainty, waiting line models, goal programming, Analytic Hierarchy Process and simulations. In this subject, the emphasis is given on the analysis and interpretation of the results provided by the models.

TBS918 Strategic Supply Chain Management

Pre-requisite: Capstone subject. This subject should be taken in the final semester of the MSL degree program

Description: This subject extends the study of Supply Chain Management from the introductory level and examines the development of organisational strategy in the context of supply chain management. The overarching framework around which the course content is organised is the supply chain management performance/ capability



continuum, which consists of three critical components: operational excellence, supply chain integration, and collaboration and virtual supply chains. Also covered is how information systems can be used to bring strategic competitive advantage to supply chains.

TBS920 International Business Strategy

Pre-requisite: It is highly recommended to take this subject after completion of at least TBS901, TBS903, TBS904 and TBS905

Exclusion: TBS984

Description: This subject provides a detailed introduction to management within an international business perspective. Business is becoming increasingly global and firms require managers who understand and can resolve the challenges faced in surviving and succeeding in this competitive, diverse and dynamic environment. The subject seeks to integrate a range of disciplines including economics, management, global finance, marketing, operations management, and socio-cultural and political sciences, into a program focussed on the application of such disciplines to real business challenges. The subject therefore intends to build the students awareness of the complexity and dynamic nature of international business, and build their capacity to think and respond strategically. Managers capable of operating effectively in this environment will have truly global skills and will enhance their career prospects in today's exciting international business context.

TBS921 Strategic Decision Making

Pre-requisite: Capstone subject. This subject should be taken in the final semester of the MBA degree program

Description: This subject is theory and case based and will provide a study of the development of strategic decision-making and its application to corporate strategy. The subject consists of three main sections: strategic analysis, strategic choice and strategy implementation. However, it is more realistic to consider these from an integrated point of view and students will be strongly encouraged to develop holistic ideas of strategic decision-making, with emphasis on solutions to actual business challenges. Students should also realise that much of the strategic thinking that will be covered in this subject is also relevant to not for profit organisations. The theme throughout the subject will be to assess strategic capability and determine appropriate strategic actions, by developing a sound understanding of the mechanisms behind industry opportunities and threats. That is not to say that a purely mechanistic view is appropriate. Creativity, divergent lateral thinking and some understanding of risk management are essential requirements. The ability to find company information and develop a sophisticated understanding of case information are also skills that will be developed to encourage an educated approach to strategic decision-making.

TBS923 Current Issues in International Business

Description: The subject provides comprehensive analyses and exploration of contemporary issues in international business environments and their implications for firms. Such rapid changes in global environments may put potentially significant impact on the international business and the home and/or host nations concerned. This subject assumes students to have a fair degree of understanding of the complexities of global, cultural,



political, economic, organizational, and financial forces of international business environments and recognize how they affect firms. As contemporary issues around international business continue to evolve, often unpredictably, challenges for firms to adjust, reshape and/or reconstruct their strategic directions and thereby organization and management structure become inevitable. This subject will introduce past, current and emerging issues in international business environments and equip students to apply theories/concepts learned to real-life practices. This subject is delivered by adopting participant-centered learning and the case method.

TBS925 Inventory Management

Description: This subject aims to provide the student with state-of-the-art knowledge of inventory management theory and practice. Topics included will be as follows: materials management; management of storage and retrieval facilities; types of inventory problems; measuring inventory performance; inventory management systems for independent demand items; influence of forecasts and uncertainties of demand and lead time; dependent demand inventory systems; multi-echelon inventory management; decision models for inventory management; simulation models of inventory management systems; and case studies of world-class inventory management.

TBS927 Process and Change Management

Description: This subject combines the process reengineering and change management. The topics covered in this context include mass customisation, business process reengineering, and change management for process change. Cases are studied to provide a unifying theme in terms of organisational change, supply chain reengineering and integration aspects.

TBS928 Logistics System

Description: Logistics Systems is an advanced course in logistics and supply chain management. It involves design and management of supply chain systems. It prepares students for logistics management positions in manufacturing, transportation and distribution firms. The application of analytical techniques, simulations and computer software to selected aspects of distribution management is explored in the course. Attention will be given to areas of network planning, inventory control, facility location, vehicle routing and scheduling of logistics systems. Mathematical models in these areas will be discussed in terms of their ability to represent the problem and usefulness to the managers. Cases will be used to demonstrate the nature of decision making problems managers' face in logistics and supply chain management in contemporary business and class discussion will take place about the repercussions of alternative decisions.

TBS930 Operations Management

Description: This subject is a study of the design, analysis, decision-making and operations of activities for the production and delivery of goods and services. Topics include: strategic issues, qualitative and quantitative forecasting, facility location, capacity and layout, production planning, scheduling, management of quality, supply chain management and e-business, just-in-time and lean manufacturing, and project management. Whilst some calculations will be part of this subject, the emphasis will be more on the managerial interpretation of the methods and results.

TBS931 Manufacturing and Operations Management

Pre-requisite: TBS908 and TBS928

Description: This course combines manufacturing and operations strategies in matching the characteristics of the operations function with the requirements of the manufacturing in order to fulfil the needs of the customer. A proper appreciation of this process requires not merely an understanding of the ideas and methods used to develop an operations strategy but also knowledge of the techniques and principles involved in its implementation.

TBS932 Service Operations Management

Pre-requisite: TBS908

Description: The purpose of this subject is to provide the student with an understanding of the basic issues, concepts, methods, tools and some quantitative models in Service Operations Management (SOM). The subject is designed for students with no previous study in Service Operations Management but aims to develop an understanding and level of skill commensurate with postgraduate study, though at an introductory level rather than that required by a professional service operations manager. Subject Aims: 1) To develop an appreciation of the significance of SOM to the success or failure of a business; 2) To be aware of and to understand some of the key activities involved in SOM; 3) To develop an insight into some of the many different tools and techniques used by Service Operations Management.

TBS933 Procurement and Inventory Management

Pre-requisite: None

Description: Today, the function that used to be called purchasing or procurement, has expanded to become supply management. Supply management is a progressive approach to managing the supply base that differs from a traditional arm's length or adversarial approach with suppliers. This subject looks at the expanded responsibility of procurement and its integration with long-term strategic corporate planning. Procurement now includes participating collaboratively in key material requirements determinations, supply management and warehousing and inventory management. It focuses on the management of supplier relations and performance. This subject incorporates all these areas in the development of procurement and supply chain management. Also included are key elements of supply chain inventory management. Also included are key elements of supply chain inventory management.

TBS934 Logistics Information Systems

Description: This subject centres on how information technologies will transform the business landscape, with a particular emphasis on logistics and supply chains. Lectures highlight logistics management process analysis, value and productivity performance measurement of information technology investments, and the impact of ERP and RFID on supply chain strategy.

TBS950 Quality in Management

Description: This subject addresses the quality issues from the supply chain perspective. It covers the following topics: the quality imperative for the open economy; concepts of quality; quality in service and manufacturing organisations; quality control and assurance; quality costs; tools of TQM; quality function deployment; six sigma implementation; principles of Taguchi methods and robust quality; international quality assurance standards; HRM in quality; case studies in quality management.

TBS951 Statistics for Quality Management

Description: Topics covered in this subject include quality theory including 'six sigma' and the 'seven tools of quality'. This subject has a comprehensive approach to statistics to meet the needs of students from diverse backgrounds. The subject provides a theoretical and practical grounding in statistical process quality (SPC). Students will be required to demonstrate their understanding of SPC using real case studies from organisations or companies selected by the student. The subject will create a direct link between statistical concepts delivered in lectures and real cases in the area of quality and a direct link between SPC and regression analysis.

TBS952 Implementing Quality Systems

Pre-requisite: TBS950

Description: This subject briefly reviews basic Quality philosophies - with an emphasis on system, cost, problem solving and people improvement. It concentrates on systems thinking as a key factor in understanding and improving quality, the development of a learning organisation, and ultimately the achievement of customer loyalty. This subject also reviews the fundamentals of the Quality organisation: ISO 9000, Six Sigma and other Quality systems that play a role in TQM. The course introduces practical Quality systems (eg: Kaizen, improvement methodologies and QI tools), Quality Function Deployment (QFD), measure of conformance and the prevention of non-conformance. The behaviour, commitment, and involvement of people in a Quality organisation are explored, including: team working, the team approach to problem solving, and the roles of management, suppliers, and customers in a Quality environment. Implementation examples are provided through a case study that features the identification and improvement of quality systems.

TBS953 Management of Service Quality

Pre-requisite: TBS950

Description: This subject explores the dimensions of successful service firms. It prepares students for enlightened management and suggests creative entrepreneurial opportunities. Outstanding service organizations are managed differently than their "merely good" competitors. Actions are based on totally different assumptions about the way success is achieved. The results show not only in terms of conventional measures of performance but also in the enthusiasm of the employees and quality of customer satisfaction. Beginning with the service encounter, service managers must blend marketing, technology, people, and information to achieve a distinctive competitive advantage. This subject will study service management from an integrated viewpoint with a focus on customer satisfaction. The material will integrate operations, marketing, strategy, information technology and

organizational issues. Finally, because the service sector is the fastest-growing sector of the economy, this course is intended to help students discover entrepreneurial opportunities.

TBS955 Quality Assurance

Pre-requisite: Capstone Subject. This subject should be taken in the final semester of the MQM degree

Description: This course provides an opportunity for specialised study within the Quality management program, by developing the following frameworks of understanding: 1) the terminologies and purposes of Quality Assurance; 2) studies of selected methodologies Quality Assurance; 3) a case study in quality assurance; 4) preparing an organisation for a selected QA accreditation.

TBS980 International Financial Management

Exclusion: TBS901

Description: This subject introduces students to financial management in an international context. The topics covered include the following: financial environment of international corporate activity; foreign exchange and derivatives markets; methods of foreign exchange risk measurement and management; overview of international financial markets and instruments; financing of foreign trade and foreign direct investments; international working capital management; investment decision making in an international context, including country risk analysis; international aspects of controlling, reporting and performance analysis; effects of government regulation on management decision making.

TBS981 Managing in Multi-National Companies

Exclusion: TBS903 Managing People in Organisations

Description: This subject will outline the factors affecting the management of people in multi-national enterprises, both the international regulatory organisations such as the International Labour Organisation and internal business criteria such as the effect of different business strategies and environments on people management practices. The course will discuss leadership, motivation, communication, performance management, diversity and corporate social responsibility as practised in multi-nationals, relating academic theory to real world examples. Students will be encouraged to think, to analyse, to discuss, to research, and to propose solutions to the problems they analyse.

TBS982 Marketing in a Global Economy

Description: The objective of this subject is to provide a background in global marketing and both a theoretical and practical perspective to advertising communications and promotion management in a global economy. Thus, by adopting the perspective of the product manager or marketing manager, the subject examines the development and implementation of advertising and promotional programmes to facilitate global marketing.

TBS983 International Business Economic Environment

Description: This subject aims to introduce to students, and develop their understanding of, those factors shaping the international economic environment in which business now operates. The subject examines the background to



globalisation and then three core areas of international business. These (trade and trade barriers, international investment and foreign exchange) will be considered separately and then together in the context of the major international institutions charged with promoting trade, investment and monetary stability.

TBS984 International Business

Pre-requisite: Capstone subject. This subject should be taken in the final semester of the MIB degree program

Exclusion: TBS920

Description: This subject provides an introduction to management within an international business perspective. Business is becoming increasingly global and firms require managers who understand and can resolve the challenges faced in surviving and succeeding in this competitive environment. Greater internationalisation of business requires firms to be more competitive, dynamic, and interdependent. Managers must understand the complexities of global cultural, political, economic, organisational, and financial forces and recognise how they affect their firm. Management challenges include dealing with the uncertain external environment, handling the increased risk of international operations, and developing appropriate international strategies. Managers capable of operating in this environment will have truly global skills and will enhance their career prospects in today's exciting international business context.

SUBJECT OFFERINGS

Subject Code	Subject Title	Spring	Summer	Autumn
CSCI925	Human Computer Interaction	✓		
ECON939	Quantitative Economic Analysis	✓	✓	✓
ENGG938	Engineering Economics		✓	
ENGG939	Engineering Logistics	✓		
ENGG951	Engineering Project Management			✓
ENGG953	Modelling of Engineering Management Systems	✓		
ENGG954	Strategic Management for Engineers and Technologists	✓	✓	✓
FIN922	Investment Management		✓	✓
FIN923	Portfolio Management	✓	✓	✓
FIN924	Financial Statement Analysis for Business		✓	
FIN925	Banking Theory and Practice	✓		✓
FIN926	Advanced Managerial Finance	✓		✓
FIN928	Multinational Financial Management	✓	✓	
FIN955	International Banking	✓	✓	✓
FIN956	Bank Lending and Securities			✓
IACT901	IT Strategic Planning			✓
IACT906	Business On-Line	✓		
IACT918	Corporate Network Planning			✓
IACT999	Emerging Topics in Information Technology	✓		TBA
ITCS937	Security, Risk Management & Control in ecommerce		✓	
MARK917	Business to Business Marketing	✓		
MARK922	Marketing Management	✓	✓	✓
MARK935	Marketing Strategy	✓	✓	✓
MARK936	Consumer Behaviour	✓	✓	✓
MARK938	Managing Services and Relationship Marketing			✓
MARK940	Marketing Communications	✓		✓
MARK959	Sales Management		✓	
MARK977	Research for Marketing Decisions		✓	✓
MARK997	Retail Marketing Management	✓	✓	
MGMT908	Human Resource Development		✓	✓
MGMT910	Strategic Management	✓	✓	✓
MGMT915	Management of Change		✓	
MGMT920	Organisational Analysis	✓		✓
MGMT930	Strategic Human Resource Management	✓	✓	✓
MGMT949	Performance Management	✓	✓	
MGMT953	Human Resource Management	✓	✓	✓
MGMT969	Job Analysis, Recruitment and Selection	✓		✓
MGMT978	Cross Cultural Management	✓	✓	✓
MIST900	International Law and Diplomacy	TBA	TBA	TBA

Correct at the time of printing (January 2013) and subject to change without notice.
The University reserves the right to withdraw a lecture class due to insufficient student enrolment.



Subject Code	Subject Title	Spring	Summer	Autumn
MIST902	Politics of International Relations and the Middle East	TBA	TBA	TBA
MIST906	Transforming MENA	TBA	TBA	TBA
MIST908	Globalization and Citizenship	TBA	TBA	TBA
MIST910	International Economic Relations	TBA	TBA	TBA
MIST913	Labor and Migration	TBA	TBA	TBA
MIST920	Social Change and Development	TBA	TBA	TBA
MIST926	Research Methods	TBA	TBA	TBA
MIST991	Thesis in International Studies	TBA	TBA	TBA
MIST992	Internship in International Studies	TBA	TBA	TBA
MIST997	Advanced Topics in International Studies: Environment	TBA	TBA	TBA
MIST998	Advanced Topics in International Studies: Terrorism	TBA	TBA	TBA
MMC910	Journalism and Society	TBA	TBA	TBA
MMC911	Introduction to News Writing	TBA	TBA	TBA
MMC912	Legal and Ethical Issues	TBA	TBA	TBA
MMC913	Introduction to Convergence Journalism (for Journalism and Media Studies)	TBA	TBA	TBA
MMC914	Advanced Reporting	TBA	TBA	TBA
MMC915	Design and Desktop Publishing	TBA	TBA	TBA
MMC916	Information Gathering	TBA	TBA	TBA
MMC917	Feature Writing	TBA	TBA	TBA
MMC920	Introduction to Professional Writing	TBA	TBA	TBA
MMC921	Writing Major Reports	TBA	TBA	TBA
MMC922	Grant Writing	TBA	TBA	TBA
MMC923	TV Journalism	TBA	TBA	TBA
MMC925	International Journalism	TBA	TBA	TBA
MMC926	Film and Cinema Studies	TBA	TBA	TBA
MMC927	Media Management	TBA	TBA	TBA
MMC928	Marketing Media	TBA	TBA	TBA
MMC929	Public Relations Research (for Public Relations and Professional Writing)	TBA	TBA	TBA
MMC930	Public Relations Publics	TBA	TBA	TBA
MMC931	Public Relations Processes	TBA	TBA	TBA
MMC932	Public Relations Programming and Production	TBA	TBA	TBA
MMC933	Case Studies in International Public Relations	TBA	TBA	TBA
MMC934	Editing Professional Writing	TBA	TBA	TBA
MMC935	Internship, Practicum, Thesis, Major Project or Professional Portfolio	TBA	TBA	TBA
TBS901	Accounting for Managers	✓	✓	✓
TBS 902	Statistics for Decision Making	✓	✓	
TBS903	Managing People in Organisations	✓	✓	✓
TBS904	Marketing Management	✓	✓	✓
TBS905	Economic Analysis of Business	✓	✓	✓
TBS906	Information Systems for Managers	✓	✓	✓



Subject Code	Subject Title	Spring	Summer	Autumn
TBS907	Financial Strategy	✓	✓	✓
TBS 909	Corporate Governance		✓	✓
TBS908	Supply Chain Management	✓	✓	✓
TBS912	Quantitative Methods for Decision Making			✓
TBS918	Strategic Supply Chain Management	✓	✓	✓
TBS920	International Business Strategy	✓	✓	✓
TBS921	Strategic Decision Making	✓	✓	✓
TBS923	Current Issues in International Business	✓		✓
TBS925	Inventory Management	✓	✓	✓
TBS927	Process and Change Management	✓	✓	
TBS928	Logistics System	✓		
TBS930	Operations Management	✓	✓	✓
TBS931	Manufacturing and Operations Management	TBC	TBC	TBC
TBS932	Service Operations Management	TBC	TBC	TBC
TBS933	Procurement and Inventory Management	✓		✓
TBS934	Logistics Information Systems		✓	
TBS950	Quality in Management	✓	✓	✓
TBS951	Statistics for Quality Management	✓		✓
TBS952	Implementing Quality Systems	✓	✓	
TBS953	Management of Service Quality	✓		✓
TBS955	Quality Assurance		✓	✓
TBS980	International Financial Management	✓	✓	✓
TBS981	Managing in Multi-National Companies	✓	✓	✓
TBS982	Marketing in a Global Economy	✓	✓	✓
TBS983	International Business Environment	✓	✓	✓
TBS984	International Business	✓	✓	✓

This Schedule is subject to change.



DEGREE PLAN

SESSION:	
Subject Code	Core/Elective

SESSION:	
Subject Code	Core/Elective

SESSION:	
Subject Code	Core/Elective

SESSION:	
Subject Code	Core/Elective

SESSION:	
Subject Code	Core/Elective

SESSION:	
Subject Code	Core/Elective

SESSION:	
Subject Code	Core/Elective

SESSION:	
Subject Code	Core/Elective

Students can enrol in a maximum of four subjects in each session through SOLS after consulting the Academic Advisor.
To enrol in additional subjects, students require permission from the Dean.



SPRING SESSION 2013 - SUBJECT TIMETABLE

	Saturday	Sunday	Monday	Tuesday	Wednesday	Thursday
6.00 - 9.00						

Check the SASS website for details of SASS workshops (www.uowdubai.ac.ae/sass) and the research website for research seminar information (www.uowdubai.ac.ae/research)

DUE DATES FOR ASSESSMENTS

Use the space provided below to record the due dates of all your assignments and tests. Refer to your subject outline for full details about your assessments.

Week	Subject	Assessment	%	Due Date
2				
3				
4				
5				
6				
7				
8				
9				
10				
11				
12				
13				

SUMMER SESSION 2013 - SUBJECT TIMETABLE

	Saturday	Sunday	Monday	Tuesday	Wednesday	Thursday
6.00 – 9.00						

Check the SASS website for details of SASS workshops (www.uowdubai.ac.ae/sass) and the research website for research seminar information (www.uowdubai.ac.ae/research)

DUE DATES FOR ASSESSMENTS

Use the space provided below to record the due dates of all your assignments and tests. Refer to your subject outline for full details about your assessments.

Week	Subject	Assessment	%	Due Date
2				
3				
4				
5				
6				
7				
8				

AUTUMN SESSION 2013 - SUBJECT TIMETABLE

	Saturday	Sunday	Monday	Tuesday	Wednesday	Thursday
6.00 – 9.00						

Check the SASS website for details of SASS workshops (www.uowdubai.ac.ae/sass) and the research website for research seminar information (www.uowdubai.ac.ae/research)

DUE DATES FOR ASSESSMENTS

Use the space provided below to record the due dates of all your assignments and tests. Refer to your subject outline for full details about your assessments.

Week	Subject	Assessment	%	Due Date
2				
3				
4				
5				
6				
7				
8				
9				
10				
11				
12				
13				

FINAL EXAM TIMETABLES

The Final Exam Timetable is printed with the subject timetable and is available on the students website (my.uowdubai.ac.ae) under the "Timetables" link. The timetable is subject to change and students are advised to check the MyUOWD website for the latest version.

SPRING SESSION 2013

Subject	Exam Date	Exam Time	Exam Location

SUMMER SESSION 2013

Subject	Exam Date	Exam Time	Exam Location

AUTUMN SESSION 2013

Subject	Exam Date	Exam Time	Exam Location

